

M-TECH

MT-700

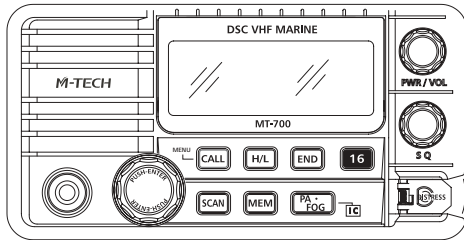

OWNER'S HANDBOOK

DECLARATION OF CONFORMITY

I hereby declare that the product:

Maritime transceiver: MT-700
+ Optional Remote Microphone: MT-RM01

satisfies all the technical regulations applicable to the product within the scope of Council Directives 73/23/EEC, 89/336/EEC and 99/5/EC:

ETSI EN 301 025-1 V1.3.1: 2007-02
ETSI EN 301 025-2 V1.3.1: 2007-02
ETSI EN 301 025-3 V1.3.1: 2007-02
ETSI EN 301 698-3 V1.1.1: 2001-05
EN 50385: 2002
EN 60945: 2002
ETSI EN 301 843-1 V1.2.1: 2004-06

All essential radio test suites have been carried out.

NOTIFIED BODY: EMCert Dr. Rasek
- Address: Boelwiese 5, 91320 Ebermannstadt, Germany
Identification Number: 0678

MANUFACTURER: Pony Electric Corporation
- Address: No. 202, 6-28, Akasaka 9-chome, Minato-ku, Tokyo 107-0052, Japan

This declaration is issued under the sole responsibility of the manufacturer and, if applicable, his authorized representative.

- Point of contact: Tadashi Watanabe, Tel: +81 (0)3 3405 5733 Fax: +81 (0)3 3405 8677



Tadashi Watanabe, President

Tokyo Japan, 17th January 2008

CE 0678 Ⓢ

NOTICE

This device is only an aid to navigation. Its performance can be affected by many factors including equipment failure or defects, environmental conditions, and improper handling or use. It is the user's responsibility to exercise common prudence and navigational judgment, and this device should not be relied upon as a substitute for such prudence and judgment. Your *MT-700* VHF radio generates and radiates radio frequency (RF) electromagnetic energy (EME). This equipment must be installed and operated in accordance with the instructions contained in this handbook. Failure to do so can result in personal injury and/or product malfunction.

Antenna Mounting and EME Exposure

For optimal radio performance and minimal human exposure to radio frequency electromagnetic energy, make sure the antenna is:

- Connected to the radio before transmitting
- Properly mounted
- Located where it will be away from people
- Located at least three feet (91 cm) from the Base Station transceiver and handsets.

TABLE OF CONTENTS

DECLARATION OF CONFORMITY	1
1. GENERAL INFORMATION	6
Introduction	6
2. LICENSE INFORMATION.....	7
2.1 Digital Selective Calling (DSC) Capability	7
2.2. Required License Information.....	7
2.3 Equipment Required	7
2.4 Equipment Supplied	8
2.5 Optional Equipment.....	8
3. BASIC RADIO COMMUNICATION PROCEDURES.....	9
3.1 Using Channel 16	9
3.2 Calling Another Vessel	10
3.3 Telephone Calls.....	10
3.4 Prohibited Communication.....	11
4. INSTALLATION.....	12
4.1 Transceiver.....	12
Dimentions	12
FM-03 Flush Mount Kit Installation	13
4.2 Antenna	13
4.3 Cable Connections	14
Power Connection	14
PA Speaker Connection.....	14
NMEA Cable.....	15
External Speaker Connection.....	15
Antenna Connector	15
Optional MT-RM01 Remote Mic Connection.....	16
5. OPERATION	17
5.1 General.....	17
5.2 Display and Controls.....	17
5.3 Basic Operation.....	18
Power On/Off	18
Volume and Squelch.....	18
Channel Selection.....	19
Channel Banks.....	19
Keypad, Transceiver.....	19

Keypad, Microphone	20
5.4 Optional MT-RM01 Remote Mic	21
Power On/Off	21
Volume and Squelch	22
Lamp	22
Contrast	22
Mic Lock	22
6. OPERATING PROCEDURES	23
6.1 Primary Calling Channel	23
6.2 Transmitting	23
6.3 Working Channel Recall	24
6.4 Transmitter Power Setting	24
6.5 Channel Scanning	24
Priority Scan	25
All Scan	25
Memory Scan	26
6.6 Menu Functions	27
6.7 Main Menu Topics	28
Directory	28
Lamp	31
Contrast	32
Data Set	32
MMSID Set	36
ATIS Set	37
Time Set	37
NMEA Set	38
GPS Alert	38
CH Name	39
Fog Freq	40
Mic Lock	40
CH Change (Automatic CH Change)	41
7. PA/FOG/INTERCOM OPERATION	42
7.1 PA Hail	42
7.2 Fog Horn	43
7.3 Intercom	44
8. DSC OPERATION	46
8.1 MMSID	46
8.2 Sending a Distress Call	47

8.3 Receiving Distress Calls	49
Distress Sent by another vessel.....	49
Distress ACK sent to another vessel.....	51
Distress Relay from another vessel.....	51
8.4 Normal DSC Calls.....	52
Individual DSC Call	52
Directory Call.....	52
Manual Call.....	55
All Ship's Call	57
Group Call	58
Position Send.....	59
Position Request	60
8.5 Receiving DSC Calls	62
Individual Call Received.....	63
Last Call Received.....	64
All Ship's Call Received.....	65
Group Call Received	67
Position Send Received.....	67
Position Request Received.....	68
9. ATIS OPERATION	69
9.1 ATIS Set	69
9.2 ATIS ID	70
10. REFERENCE.....	71
10.1 Maintenance	71
10.2 Special Functions.....	71
Clear Memory Channels	71
New Microphone.....	71
Printer Operation	71
10.3 Troubleshooting	72
10.4 Specifications.....	73
10.5 Channel Assignments.....	77

1. GENERAL INFORMATION

Congratulations on your purchase of the *MT-700*. It is an advanced marine VHF communication transceiver offering Digital Selective Calling, a separate Channel 70 receiver, an easy to use four line LCD display, PA Hail/Fog Horn functions, and optional Remote Mic capability.

NOTICE

Unauthorized changes or modifications to this equipment may void compliance with Regulatory Agency Type Acceptance. Any changes or modification must be approved in writing by the manufacturer.

NOTICE

This radio transceiver has been tested and complies with EN-301 025-1 v1.3.1 (February 2007). This specification provides reasonable protection against harmful interference in a normal installation. This radio generates, uses and radiates radio frequency energy and, if not installed and used in accordance with the instructions, may cause harmful interference to other marine electronic equipment. However, there is no guarantee that interference will not occur in a particular installation. If this radio does cause harmful interference to marine electronic equipment, which can be determined by turning this radio Off and On, the user is encouraged to try to correct the interference by one or more of the following measures:

- Reorient or relocate the antenna.
- Increase separation between this radio and other marine electronic equipment.
- Connect this radio to a power source different from that of other marine electronic equipment.
- Consult your dealer or an experienced technician for help.

Introduction

Your *MT-700* VHF Transceiver is designed for operation in the marine VHF FM frequency band. The operating frequency range is 156.025 to 162.000 MHz which includes all currently allocated International channels.

The transceiver has Digital Selective Calling (DSC) capabilities conforming to EN-301 025-1 v1.3.1 operation. Distress, All Ships, Individual and Group DSC call formats are supported. There are thirty two memories for storing incoming DSC calls and thirty two for your personal DSC call directory.

Also transceiver has the built-in PA Hail/Fog Horn features, and full remote control

capability including Intercom operation with optional *MT-RM01* Remote Mic.

Other features include Position Send/Request, all channels scanning, priority channel scanning, memory channel scanning, one button instant access to channel 16 and an alphanumeric keypad on the microphone.

2. LISENCE INFORMATION

Your *MT-700* complies with European Standard EN-301 025-1 v1.3.1. Users must know and comply with all applicable rules and regulations for the country or countries having jurisdiction over waters where your transceiver is operated. Depending upon national regulations, a station license may be required for a VHF transceiver and an operator license or permit may be required for an individual to operate a VHF transceiver.

Prior to using your *MT-700* inquire with your national radio communication authorities.

2.1 Digital Selective Calling (DSC) Capability

You must obtain a nine-digit maritime mobile service identity (MMSI) and program it into the unit before you transmit. To obtain an MMSI, you will be asked to provide certain information about your ship. It is important that you obtain an MMSI because National Coast Guards and other search and rescue (SAR) agencies use this information to help speed search and rescue operations.

2.2 Required License Information

The following information pertaining to your transceiver is necessary if completing a station license application

Output Power.....	1 Watt (low) and 25 Watts (high)
Emission	16K0F3E, 16K0G3E
Frequency Range.....	156.025 to 162.000 MHz
Meets Essential Requirements of RTTE DIRECTIVE (Declaration of Conformity)	

2.3 Equipment Required

The minimum equipment required for two way voice and DSC VHF radio communication with vessels and shore stations includes:

- VHF radio communication transmitter and receiver designed and approved for marine VHF communication use.

- VHF antenna and connecting cable. Use a good quality unity gain antenna for best range performance.
- Power source suitable for the VHF transmitter and receiver.
- For PA Hail and Fog Horn features to function, connection to an extra PA Speaker (30W nominal at 13.6V/4Ohm).
- For Digital Selective Calling (DSC) VHF communication radios, connection to a GPS receiver that provides latitude and longitude coordinates and UTC time for distress messages.

2.4 Equipment Supplied

- *MT-700* Marine VHF Transceiver.
- Microphone with alphanumeric keypad.
- Mounting Bracket with knobs.
- Power Cable with in-line fuse (6.3 Amp).
- NMEA Data Cable.
- *FM-03* Flush Mount Kit.

2.5 Optional Equipment

- *MT-RM01* Remote Mic.

3. BASIC RADIO COMMUNICATION PROCEDURE

Distress or emergency calls may be made either manually or automatically. Sending distress calls automatically uses the Digital Selective Calling (DSC) functions of your transceiver and requires an operating and properly connected navigation receiver. The following procedures are for sending voice distress messages manually. Sending an automatic distress call is described in the DSC section of this manual.

3.1 Using Channel 16

Channel 16 is the Calling and Distress channel. An emergency may be defined as a situation that threatens human life or property. In such situations, make sure your transceiver is turned On and set the channel selector to Channel 16. Then use the following procedure to make a distress call. The total transmission should not exceed 1 minute.

1. Press the microphone Push To Talk button. Speak slowly and clearly into the microphone: “Mayday, Mayday, Mayday, this is your vessel’s name, your vessel’s name, your vessel’s name”.
2. Then repeat once: “Mayday, your vessel’s name”.
3. Continue by reporting your position in latitude and longitude or by reporting your bearing (true or magnetic, specify which) and distance from a prominent or well known landmark, geographic feature or aid to navigation.
4. Explain the nature of your emergency (fire, sinking, collision, grounding, health condition, injury, etc.).
5. Report the kind of assistance you require (fire, medical aid, pumps, etc.).
6. State the number of people aboard and the condition of any injured.
7. Estimate the seaworthiness and condition of your vessel.
8. Describe your vessel: length, type, color and any distinguishing feature.
9. End the message by saying “Over”. Release the Push To Talk button and listen for a reply.
10. If there is no reply, repeat the above message procedure. If there is still no response, try another channel.

3.2 Calling Another Vessel

Channel 16 may be used to establish initial contact with another vessel. However, its most important use is for voice emergency messages. Channel 16 must be monitored at all times except when engaged in actual communication on another channel. Channel 16 is monitored by international search and rescue (SAR) authorities, National Coast Guards and by other vessels. Use of Channel 16 for calling or hailing must be limited to initial contact only. Calling should not exceed 30 seconds and may be repeated 3 times at 2 minute intervals.

Prior to making contact with another vessel, determine which channel will be used for continued communication after the initial contact. Monitor the desired channel for traffic and, when clear, switch to Channel 16 to make initial contact.

Listen for traffic on the Calling Channel (16). If clear, press the Push To Talk (**PTT**) button on the microphone. Speak the name of the vessel you are calling followed by "This is" and the name of your vessel and your call sign. Release the **PTT** and listen for a reply. When the other vessel returns your call, acknowledge the call with "go to", the number of the new channel and "over". Switch to the new channel and listen for traffic. If necessary, wait for traffic to clear, and then call the other vessel. As communication proceeds, end each transmission with "over". When communication with the other vessel is completed, end the last transmission with your call sign and the word "out". It is not necessary to end each transmission with your call sign, just give your call sign at the beginning and end of each contact.

Remember to switch to Channel 16 when not actively communicating on another channel.

3.3 Telephone Calls

You may use your *MT-700* transceiver to make telephone calls to persons on shore. To do so requires the services of marine operators who operate on designated Public Correspondence channels. There are several channels designated for this type of traffic and to determine the channel being used in your area, ask someone with local knowledge, contact a Harbor Master or other marine authority.

Call the marine operator and identify yourself with your vessel's name. Normally you contact a marine operator on their working channel rather than making initial contact on Channel 16. The marine operator will ask for your intentions and establish a payment method for the call (collect, credit card, etc.). When arrangements are complete, your radio communication will be patched into the telephone line. In conversing with a person on the phone it is important to use

normal radio communication procedures. You should say "over" and release the **PTT** button at the end of each transmission. Both parties cannot speak simultaneously as on normal telephone calls.

Usually there is a fee for marine operator services which is charged in addition to any other charges associated with the call.

3.4 Prohibited Communication

The following communications are prohibited by regulations and violators are subject to penalties.

- False distress or emergency messages (including false DSC distress).
- Messages to "any vessel" except in emergencies and radio tests.
- Messages to or from a vessel on land.
- Transmission while on land.
- Obscene, indecent, or profane language.

4. INSTALLATION

4.1 Transceiver

Your *MT-700* Transceiver is designed to withstand the rigors of the marine environment. However, selecting a mounting location affording some protection from the elements will prolong the life of connectors, controls and the liquid crystal display (LCD).

Select a location within easy reach and view of the operator and away from your vessel's compass. Locate the microphone to avoid entanglement with steering or engine controls, both when in use and when stowed. Also, consider routing of antenna, power and NMEA interface cables. Mount the transceiver securely to a solid surface.

Dimensions

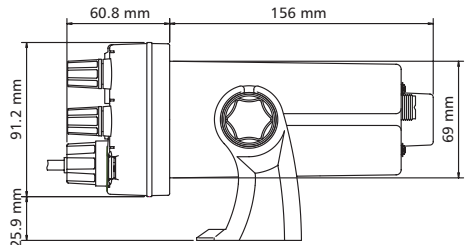
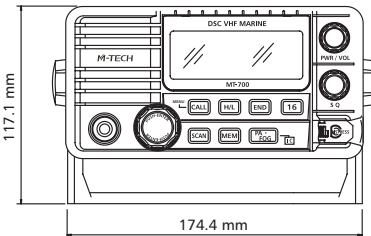
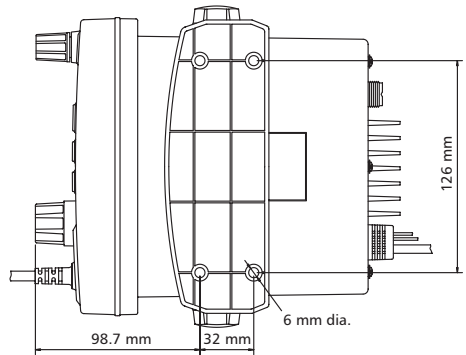
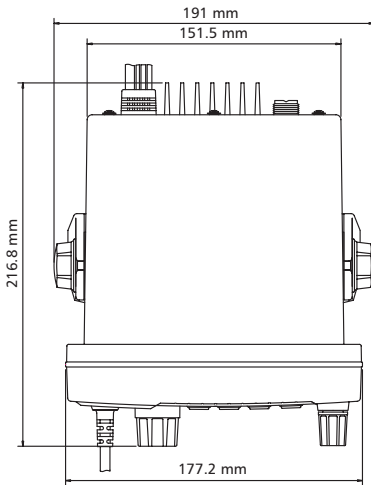

FM-03 Flush Mount Kit Installation

1. Cut the dash board using a template sheet.
2. Set the transceiver in the cut dash board.
3. Rotating the longer screw and set it to the each hole of the plastic mount block. Firmly attach the bolt foot rotating to the top of the each screw. (See Fig. 1)
4. Firmly fix the plastic mount block on the either side of the transceiver using shorter screw. Don't forget to attach the washer. (See Fig. 2 and Fig. 3)
5. Fasten the each longer screw to fix the transceiver to the dash board firmly. (Fig. 4)
6. The same works should be done to the other side too.

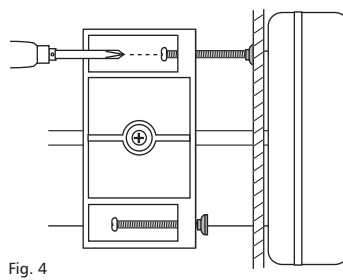
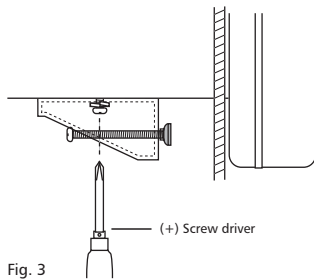
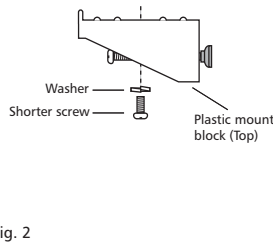
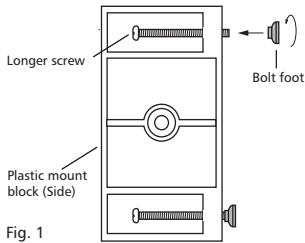

4.2 Antenna

Proper installation of a quality VHF antenna is very important to reliable radio communication. A good quality unity gain antenna is recommended for maximum range performance. In general, antennas should be located as high as practical and separated as much as possible from other antennas and structures. The minimum distance to other objects is 1 meter. Route the antenna cable away from other electronic equipment and do not bundle the antenna or power cable with other wiring, especially transducer cables for depth sounders and fish finders. For cables longer than 10 meters, RG-8/U coaxial cable must be used. Mount the antenna and install the connector(s) in accordance with manufacturer's instructions. Connect the antenna cable to the RF output connector on the rear panel of the transceiver.

4.3 Cable Connections

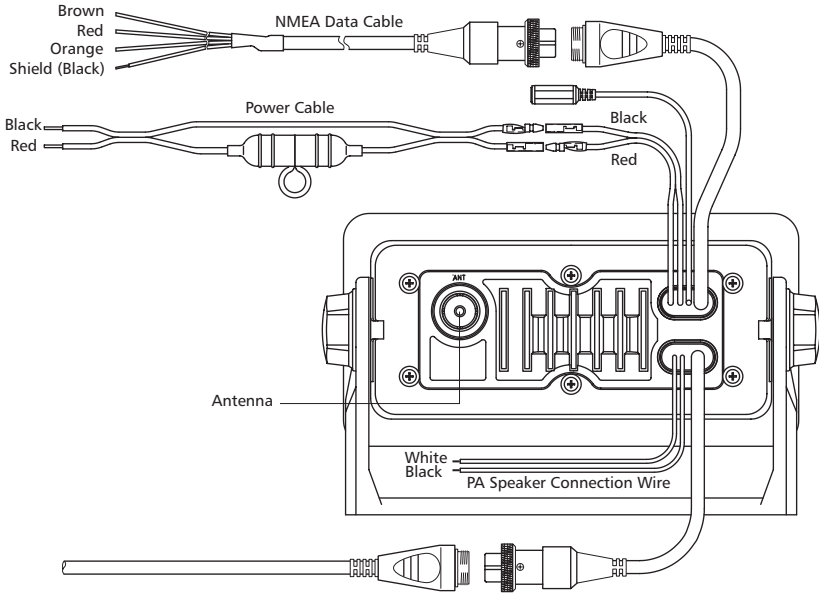

MT-700 Rear Panel Connections

Power Connection

CAUTION

Reverse polarity connections can damage your transceiver

The power cable for your transceiver must be connected to the ships main power buss. Use the 6.3 Amp in-line fuse provided. Connect the Red wire to the positive (+) terminal and the Black wire to the negative (-) terminal. Connect the barrel terminals on the power cable to the matching color wires and terminals extending from the rear panel of the transceiver.

PA Speaker Connection

In order for PA Hail/Fog Horn features of your MT-700 transceiver to function, extra PA Speaker (30W nominal at 13.6V/4Ohm) must be connected. Connect the White (+) wire and Black (-) wire on the transceiver’s rear panel to the extra PA Speaker.

Wire Color	Description	Connection
White	PA Speaker (+)	Connect to extra 4 Ohm PA Speaker
Black	PA Speaker (-)	Connect to extra 4 Ohm PA Speaker

NMEA Cable

In order for the position reporting/transferring features of your *MT-700* transceiver to function, an operating GPS navigation receiver must be connected to your transceiver. The supplied data cable plugs into the 8 pin connector on the transceiver's rear panel and the other end connects to the NMEA data output/input from your GPS navigation receiver. Your GPS must adapt for the \$GPRMC/GGA NMEA data sentence. Refer to your navigation receiver manual for information about its NMEA output/input settings and connections.

Wire Color	Description	Connection
1. Brown	NMEA Rx (+)	Connect to NMEA Tx (+) of GPS
2. Red	NMEA Rx (-)	Connect to Ground/NMEA Tx (-) of GPS
3. Orange	NMEA Tx (+)	Connect to NMEA Rx (+) of GPS
4. Shield	Ground/NMEA Tx (-)	Connect to Ground/NMEA Rx (-) of GPS

Pins 3 & 4 reserved for DSC/PC printer interface
Pins 5-8 reserved for Flash programmer

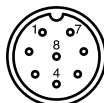

External Speaker Connection

Provision for connecting an external speaker is provided on the rear panel. Use an 8 Ohm speaker rated for at least 3 Watts and suitable for the environment at the chosen location.

3.5 mm Phone plug	
Tip	Audio Out (+)
Body	Audio Out (-)

Antenna Connector

The transceiver is fitted with a type SO 239 female connector which mates with a PL 259 male connector supplied with VHF marine antennas.

Optional MT-RM01 Remote Mic Connection

In order for full remote control to function, optional *MT-RM01* Remote Mic must be connected to your transceiver using the supplied 10m Extension Cable.

Connect the 10m Extension Cable to the Remote Mic Connector on the transceiver's rear panel, and then tighten the cable nut.

You can also connect an External Speaker to the *MT-RM01* Remote Mic.

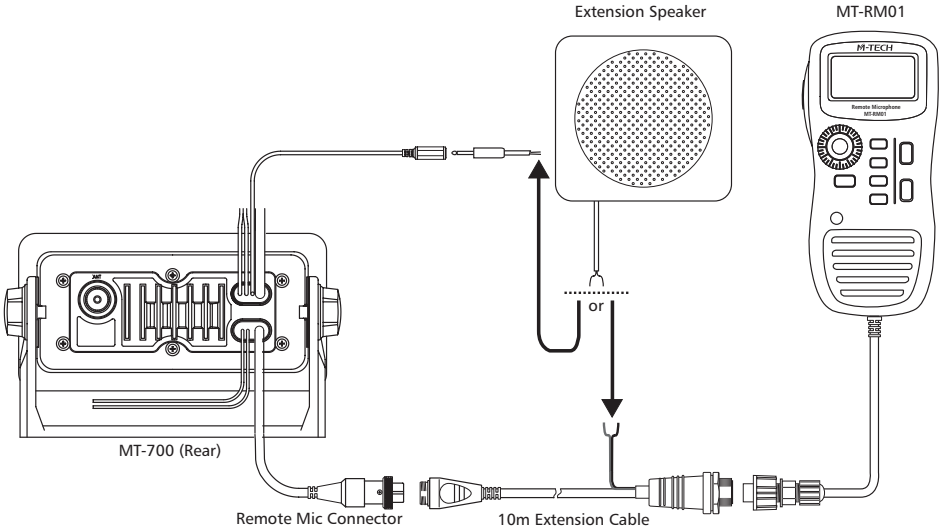

MT-RM01 Remote Mic and External Speaker Connections

Other end of 10m Extension Cable can be installed into a wall as a wall socket:

1. Make a large hole, and drill 3 screw holes on the wall using template sheet.
2. Insert the 10m Extension Cable into a large hole.
3. Connect the Gasket and Mounting Base to the 10m Extension Cable using the Nut.
4. Mount the Mounting Base to the wall using 3 screws.

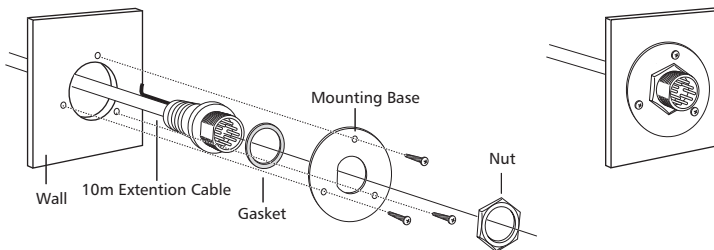

Wall Mount Kit Installation

5. OPERATION

5.1 General

Your *MT-700* is an advanced marine VHF communication transceiver offering the safety and convenience of Digital Selective Calling in addition to all the useful features found in the best conventional VHF radios.

5.2 Display and Controls

The transceiver is operated using the front panel controls, the keypad, the Push To Talk (PTT) button and a keypad on the microphone. The 4-line LCD displays the current operating status, menus for selecting functions, and settings for optional features. The microphone has a keypad for changing channels and selecting functions.

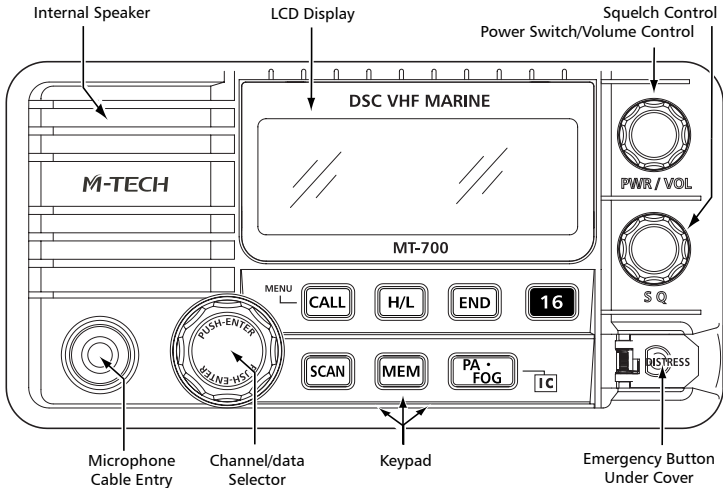

MT-700

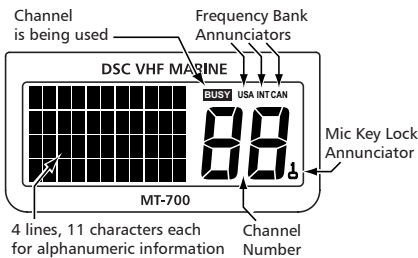

Liquid Crystal Display

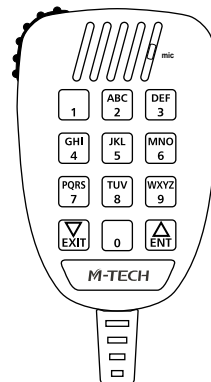

MT-700

5.3 Basic Operation

Power On/Off

Power to the transceiver is controlled with the **PWR/VOL** knob.

To turn the transceiver On:

- Press and hold the **PWR/VOL** knob. The LCD backlight illuminates and the Power-On screen appears.

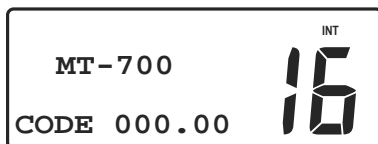

Power-On Screen

After approximately two seconds, the Normal Communication screen appears in the display.

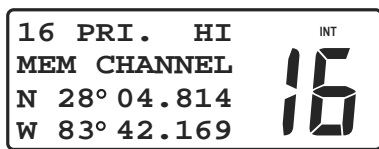

Normal Com Screen
with GPS Connected

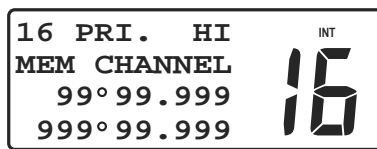

Normal Com Screen
w/o GPS connected

To turn the transceiver Off:

- Press and hold the **PWR/VOL** knob until the LCD turns off.

Volume and Squelch

The Volume and Squelch controls have each knob. They are independent controls but work together to control audio output from the speaker. The volume control sets the loudness of sound from the speaker and the squelch control is used to mute background noise when no received signals are present.

To properly set the Volume and Squelch controls:





- Rotate the **SQ** knob fully CCW.
- Rotate the **PWR/VOL** knob CW until background noise is plainly heard.
- Slowly rotate the **SQ** knob CW until the noise is muted (squelched). Then adjust the control slightly more CW (approximately 1/8 turn). Use care not to set the **SQ** control more CW than necessary or weak signals may not be heard.

Some channels exhibit more background noise than others, so it may be necessary to readjust the squelch setting when changing channels or when scanning.

Channel Selection

When the transceiver is turned On, the Primary Calling Channel (channel 16) is selected.

There are three ways to change channels:

- Rotate the  (**SELECT/ENT**) knob, press and hold the  or  keys, or directly enter the channel number using the numeric keys on the microphone. The  and  keys will always change channels except when being used to enter or edit a directory page.

Channel Banks

Your *MT-700* is designed for use with the International VHF marine channel frequencies plus authorized local channel frequencies. Only authorized dealers can program other approved country channels, where specifically allowed by government regulations, by using the 8 pin com connector.

Keypad, Transceiver

A tone is emitted each time a key is pressed. A three beep error tone is emitted when a key is not allowed. Some functions require a key to be pressed and held. After the hold period times out, a second tone is emitted as the function is entered. The basic purpose for each key follows. Detailed usage of keys is described in operating procedures for the transceivers various functions.



Initiates DSC operation screens by pressing. Also opens menu to select optional settings to personalize your transceiver's operation by pressing and hold.



Used to complete editing or selection of options from menu.



Used to toggle transmitter power between 25 watts and 1 watt output.

Certain channels are restricted to 1 watt maximum power and will cause the error beep if the **HI/LO** key is pressed.

- 16** Selects the Primary Calling Channel 16 or the last channel used. Also, cancels DSC and Emergency/Distress calls.
- SCAN** Can be used alone or with the **MEM** key to select Priority Scan, Memory Scan or All Scan.
- MEM** Stores channels in the scan memory bank, and when used with the **SCAN** key, starts Memory Scan.
- END** Cancels DSC calls and Emergency/Distress calls.
- PA • FOG** Initiates PA/FOG menu screen by pressing. Also initiates Intercom operation mode by pressing and hold.

Keypad, Microphone

The microphone keypad is used to change channels by directly entering the actual channel number with the **0** through **WXYZ 9** keys. The **ENT** or **EXT** keys step or scroll to a new channel. The microphone keys are used to enter alphanumeric characters and symbols shown in the following chart.

Microphone Keys									
0	1	ABC	DEF	GHI	JKL	MNO	PQRS	TUV	WXYZ
0	1	2	3	4	5	6	7	8	9
Alphanumeric Character Sequence									
0	1	A	D	G	J	M	P	T	W
Space	-	B	E	H	K	N	Q	U	X
(,	C	F	I	L	O	R	V	Y
)	.	?	!	:	#	'	S	&	Z
%	/	2	3	4	5	6	7	8	9

5.4 Optional MT-RM01 Remote Mic

The optional *MT-RM01* Remote Mic works as a second station of your *MT-700* transceiver. You can operate all functions including DSC, PA Hail, Fog Horn and Intercom. It has common usability to your *MT-700* transceiver (except some operations) with same Keypad, **SELECT/ENT** dial and four lines LCD display.

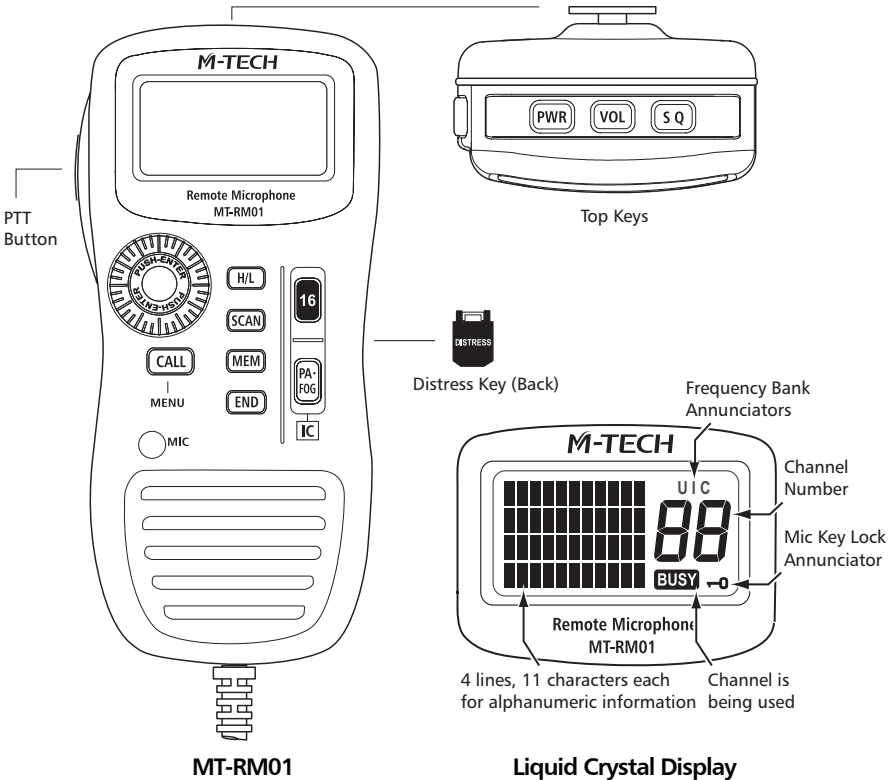

Power On/Off

To turn the *MT-RM01* Remote Mic On/Off:

- Press and hold the **PWR** key.

NOTE

Power On/Off of *MT-RM01* Remote Mic is working together with your *MT-700* transceiver. When powering On/Off the *MT-RM01* Remote Mic, *MT-700* transceiver is also powered On/Off. When powering On/Off the *MT-700* transceiver, *MT-RM01* Remote Mic is also powered On/Off.

Some controls like **VOL**ume, **SQ**uelch, **LAMP**, **CONTRAST** and **MIC LOCK** work separately from your *MT-700* transceiver:

Volume and Squelch

The **VOL**ume and **SQ**uelch controls work separately from *MT-700* transceiver.

To set the **VOL** control:

- Press the **[VOL]** key. Rotate the **SELECT/ENT** dial to increase or decrease the volume.

To set the **SQ** control:

- Press the **[SQ]** key. Rotate the **SELECT/ENT** dial to increase or decrease the squelch level.

LAMP

The **LAMP** adjustment works separately from *MT-700* transceiver, but how to adjust is same as *MT-700*. See the **LAMP** topic of **6.7 Main Menu Topics** section.

CONTRAST

The **CONTRAST** adjustment works separately from *MT-700* transceiver, but how to adjust is same as *MT-700*. See the **CONTRAST** topic of **6.7 Main Menu Topics** section.

MIC LOCK

In order to prevent accidental key operation, Keypad (except **PTT**, **DISTRESS** keys and **SELECT/ENT** dial) of your *MT-RM01* Remote Mic may be locked.

- Press and hold the **SELECT/ENT** dial. **MIC LOCK** annunciator appears in the display.

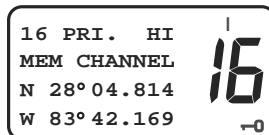

Mic Key Lock annunciator

To unlock the Keypad:

- Push and hold the **SELECT/ENT** dial until **MIC LOCK** annunciator is gone.

6. OPERATING PROCEDURES

6.1 Primary Calling Channel

VHF Channel 16 (156.8 MHz) is the Distress Safety and Primary Calling Channel. All vessels, not actively engaged in communication, are required to maintain a listening watch on Channel 16.

6.2 Transmitting

The transmitter is activated, for normal voice communications, by pressing the Push To Talk (**PTT**) button on the microphone. Always listen for moment on a channel before transmitting. If the channel is busy, do not transmit until the channel is clear. For DSC calling and Distress calls, the transmitter is activated automatically during the appropriate operating procedure. After DSC contact is established, proceed as in normal voice communication. Continuous transmitter operation is limited to five minutes and the transmitter will automatically stop.

To establish normal voice communication:

- Press the  key to select the Primary Calling Channel. The Primary Calling Channel is 16. The Primary Calling Channel number appears in the upper left corner of the display.
- Listen on the Primary Calling Channel to make sure the channel is clear.
- Press the **PTT** button. Speak directly into the microphone in a normal tone of voice –clearly–distinctly. Say “(name of vessel being called) THIS IS (your vessel’s name and call sign).”
- Release the **PTT** button and listen for a reply.
- Once contact is made on the Primary Calling Channel, each vessel must switch to a working channel to continue conversation. Refer to the channel chart for proper usage.
- After communication is completed, each vessel must give its call sign or vessel name and switch to the Primary Calling Channel and resume listening watch.

6.3 Working Channel Recall

Rather than using the **SELECT/ENT** knob or microphone keys to change channels, this feature allows quick switching between the last working channel and the current primary channel.

To quickly switch between the last working channel and the Primary Calling Channel:

- Use the **SELECT/ENT** knob or microphone keys to select a working channel, such as channel 68.
- Press the **16** key momentarily. The current primary channel number appears in the channel number display.
- Press the **16** key again momentarily. The working channel number appears in the display. Each time the key is pressed, channel selection toggles between the primary channel and the working channel.

6.4 Transmitter Power Setting

The transmitter has two power settings, 25 watts or 1 watt, which are indicated by **HI** or **LO** appearing in the upper line of the display. The normal power setting is **HI** for all channels where 25 watts is allowed. Use the 1 watt setting for communication with nearby vessels (bridge-to-bridge) or facilities (drawbridges).

- Press the **H/L** key to toggle transmitter power between 25 watts and 1 watt output.

SPECIAL NOTE

Channels 15, 17, 75 and 76 are restricted to 1 watt maximum power and will cause the error beep if the **HI/LO** key is pressed.

6.5 Channel Scanning

There are three channel scanning modes; Priority Scan, All Scan and Memory Scan. In the Priority Scan mode, Channel 16 is checked for activity every 2 seconds, even if, the scan is halted by traffic on a working channel. When scanning is halted by traffic, the scan pauses while the channel is active. Scanning resumes, after a brief delay when the channel is clear. If the **PTT** is pressed, in reply to a received signal, scanning is cancelled.

Priority Scan

The Priority Scan function scans the Primary Calling Channel and the last selected working channel.

To select Priority Scan:

- Press the **SCAN** key. **PSCAN** appears in the upper line of the display and the two scanned channel numbers appear alternately in the display.

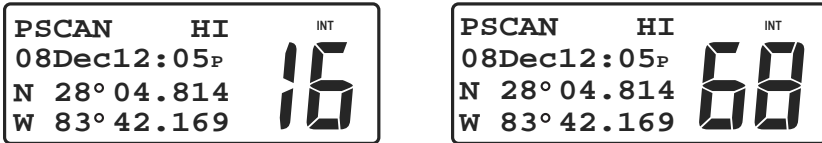

Priority Scan Sequence

To exit Priority Scan:

- Press the **SCAN** key or press the **16** key.

All Scan

The All Scan function scans all channels except channel 70. Channel 70 is the Digital Selective Calling (DSC) channel. Voice traffic is not permitted on this channel. If noisy or busy channels interfere with scanning, the interfering channels may be temporarily removed from the scan sequence.

To select All Scan:

- Press and hold the **SCAN** key for 2 seconds. **ALLSCAN** appears in the upper line of the display. The scanned channel numbers appear in sequence in the channel number display.

To Exit All Scan:

- Press the **SCAN** key or press the **16** key.

To delete channels from the scan sequence:

- Push and hold the **SELECT/ENT** knob while the scan is halted on the offending channel. Turning the transceiver Off and On, restores all channels to the scan sequence.

Memory Scan

Memory Scan allows the user to create and scan a bank of preferred channels. Channels may be added to or removed from the memory channel bank as desired. Memory channels are stored individually and may be deleted individually, or the entire bank may be deleted. If the **PTT** button is pressed, the transceiver exits scanning and normal communication is resumed.

To create or add channels to the memory channel bank:

- Press the **MEM** key. The Memory Scan channel bank appears in lower two lines of the display. If no channels have been previously added to the bank, the Primary Calling Channel (16) is displayed. Otherwise, up to six channel numbers appear. A plus sign (+) at the end of the lower line indicates more than six channels are stored in the bank. Press the **MEM** key again to advance to the next page of channels. The memory channel bank can hold all usable voice communication channels.



Memory Scan Bank

Default Page

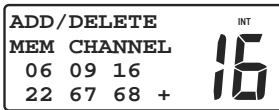

Memory Scan Bank

Page Full



Memory Scan Bank

Next Page

- Rotate the **SELECT/ENT** knob or microphone keys to select a desired channel to add to the memory channel bank.
- Press and hold the **MEM** key for about two seconds. The selected channel is stored and the channel number appears in the memory channel bank. Repeat the select and store process to add more preferred channels. As each channel is added, the existing channels in the bank shift as necessary to display the new channel number in the bank.

When in the normal communication mode, as channels are selected, **MEM CHANNEL** appears in the second line of the display if the selected channel is stored as a memory channel.

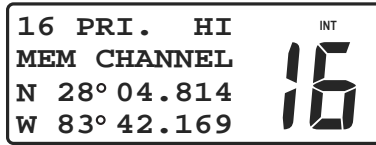

Memory Channel Display

To remove channels from the memory channel bank:

- Press the **MEM** key. The Memory Scan channels appear in the display.
- Rotate the **SELECT/ENT** knob or use microphone keys to select a displayed channel.
- Press and hold the **MEM** key for about two seconds. The selected channel is deleted and the channel number is removed from the memory channel bank.

To remove all channels from the memory channel bank:

- Turn the transceiver Off.
- Press and hold the **MEM** key while turning the transceiver On. The memory channel bank is erased except for Channel 16 which remains.

To start Memory Scan:

- Press the **MEM** key. The Memory Scan channel bank appears in the display.
- Press the **SCAN** key. **MSCAN** appears in the upper line of the display. The scanned channel numbers appear in sequence in the channel number display.

6.6 Menu Functions

Menus are used to customize optional settings to individual preference. The multilevel menu system is a list of topics that, when selected individually, offer options or additional related topics from which to choose. Changes to menu settings are stored and remain in force until changed again.

To navigate through menus:

- Press and hold the **CALL** key. The Main Menu appears in the display. **DIRECTORY** is always the first topic displayed on the Main Menu list.

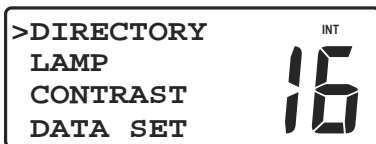

Main Menu Topics

To select a topic in the menu list:

- Rotate the **SELECT/ENT** knob to move the cursor > to the desired topic. There are more topics than can be displayed at one time, so the list scrolls as the cursor is advanced beyond the top or bottom of the list.

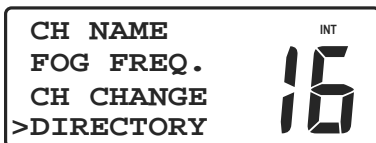

More Main Menu Topics

- With the cursor on the desired menu topic, press the **SELECT/ENT** knob. Options or edit settings for the topic appear in the display.
- Rotate the **SELECT/ENT** knob to move the cursor to the desired setting.
- Push the **SELECT/ENT** knob to store the new setting.

If you change your mind:

- Before pressing the **SELECT/ENT** knob while in an editing mode, press and hold the **CALL** key to backup to the next higher menu level.

To exit the menus and return to communication functions:

- Press the **16** key. If the **SELECT/ENT** knob was not pushed to store a new value, no changes are made.

6.7 Main Menu Topics

DIRECTORY

The DSC Calling Directory is a list of names and corresponding MMSID's that you enter and store for making DSC calls (32 ID's maximum). Entries to the list can be added or edited as necessary to keep your directory current.

To add a name and MMSID to the directory:

- Press and hold the **CALL** key. The **DIRECTORY** topic appears in the display.
- Push the **SELECT/ENT** knob. If the directory is empty, the screen appears blank except for the channel number. If previous entries appear, move the cursor to an empty line. If no empty line is found, the directory is full and a previous entry must be overwritten.
- Push the **SELECT/ENT** knob. The **DIRECTORY NAME/ID** screen appears with a blinking cursor next to the name line.

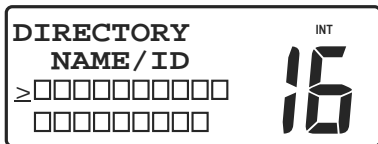

Name and ID Screen

- Push the **SELECT/ENT** knob or **ENT** key to move the cursor to the first character of the name line.

SPECIAL NOTE







Characters are entered in the name and ID fields using either the **SELECT/ENT** knob or the microphone keys.

All letters in the alphabet, a space, and the numbers 0~9, plus punctuation marks and some symbols may be used. The space character follows Z in the alphabet when using the **SELECT/ENT** knob. Only numbers are allowed in the ID field.









The following table shows the characters that may be entered in the name field using the microphone keys.

Microphone Keys									
0	1	ABC	DEF	GHI	JKL	MNO	PQRS	TUV	WXYZ
0	1	A	D	G	J	M	P	T	W
Space	-	B	E	H	K	N	Q	U	X
(,	C	F	I	L	O	R	V	Y
)	.	?	!	:	#	'	S	&	Z
%	/	2	3	4	5	6	7	8	9

Several additional special characters are available when entering the name using the **SELECT/ENT** knob.

- Use the **SELECT/ENT** knob or microphone keys to select the desired letter, number or symbol for the first character.
- If using the **SELECT/ENT** knob, push the **SELECT/ENT** knob or  key after each character is selected to enter the character and advance the cursor to the next character position.
- If using the microphone keys, press the appropriate key repeatedly until the desired character is displayed at the cursor position. Then press the appropriate key for the next character. The cursor automatically moves to the new position. When entering the same character in two or more successive character positions, use the **SELECT/ENT** knob or  keys to advance the cursor.
- Use the  key if necessary to backspace the cursor.
- Up to ten characters are allowed in the name, but only one is required. Enter enough characters to positively identify the entry.
- After the last character in the name is selected and entered, push the **SELECT/ENT** knob or  key again. The cursor moves to the MMSID line.
- Push the **SELECT/ENT** knob or  key to move the cursor to the first digit position in the MMSID line.
- Enter the first number in the MMSID. Only numbers 0~9 are allowed in the MMSID.
- Press the next microphone number key or push the **SELECT/ENT** knob to store the selected digit and move the cursor to the next digit position.
- Continue to select and store digits until the complete MMSID is entered. After the last MMSID digit is entered, the cursor returns to the name line of the display.
- If the name and ID are correct for this directory entry, press and hold the  key to save the data and exit. The directory list appears in the display showing the new entry by name only. The MMSID does not appear in the directory list.

To edit an existing name or MMSID in the directory:

- Press and hold the  key. The **DIRECTORY** topic appears in the display.
- Push the **SELECT/ENT** knob. DSC Calling Directory entries appear in the display. The directory stores a maximum of 32 entries which are displayed four at a time.
- Use the **SELECT/ENT** knob to move the cursor to the entry name for editing.
- Push the **SELECT/ENT** knob. The **DIRECTORY NAME/ID** screen appears presenting the name and MMSID for the selected directory entry. The blinking cursor is positioned at the start of the entry's name.
- Push the **SELECT/ENT** knob or  key. The cursor becomes an underline instead of a blinking square and moves to the first character position.
- Use the **SELECT/ENT** knob to move the underline cursor to the character position needing change.
- Push the **SELECT/ENT** knob or  key. The blinking cursor appears.
- Use the **SELECT/ENT** knob or microphone keys to change the contents of the character to the new value.
- When new value is correct, press the **SELECT/ENT** knob or the  key. If more characters in the same line need changing, use the **SELECT/ENT** knob or  or  key to move the blinking cursor to the next desired character. If no more changes are desired on the same line, press and hold the  key to move the cursor back to the start of the line.
- When both the name and MMSID are correct, press and hold the  key to save the data and exit to the directory listing.

LAMP

Allows adjustment of illumination for the LCD display, keypad and microphone keypad.

- Press and hold the **CALL** key. Menu topics appear in the display.
- Use the **SELECT/ENT** knob to position the cursor on the **LAMP** topic.
- Push the **SELECT/ENT** knob. The **BRIGHTNESS** adjust screen appears in the display.



Brightness Control

- Use the **SELECT/ENT** knob or microphone keys 0~3 to change the setting.
- Push the **SELECT/ENT** knob or press and hold the **CALL** key to store the setting and exit.

CONTRAST

Allows adjustment of LCD display contrast for best readability in varying lighting conditions.

- Press and hold the **CALL** key. Menu topics appear in the display.
- Use the **SELECT/ENT** knob to position the cursor on the **CONTRAST** topic.
- Press the **SELECT/ENT** knob. The **CONTRAST** adjust screen appears in the display.



Contrast Control

- Use the **SELECT/ENT** knob or microphone keys 0~7 to change the setting.
- Press the **SELECT/ENT** knob or press and hold the **CALL** key to store the setting and exit.

DATA SET



Provides On/Off control for display of Lat/Lon, Date/Time, Speed/Course, and

Manual Lat/Lon. Also, provides for entry of Manual Lat/Lon coordinates.

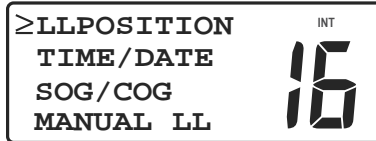
- Press and hold the **CALL** key. Menu topics appear in the display.
- Use the **SELECT/ENT** knob to position the cursor on the **DATA SET** topic.
- Push the **SELECT/ENT** knob. The Data Set menu selections appear in the display.



Data Set Selections

- Use the **SELECT/ENT** knob or  or  to select either **LLPOSITION**, **TIME/DATE** or **SOG/COG**. **MANUAL LL** is described separately.
- Push the **SELECT/ENT** knob. The On/Off option is displayed.
- Use the **SELECT/ENT** knob or any microphone key to select either On or Off.
- Push the **SELECT/ENT** knob to store the selection and exit to the previous menu.

The **MANUAL LL** data item has 3 options, On/Off/Set. The Set option is used to manually enter your approximate Lat/Lon position and time of day for distress messages if your GPS is not connected or not functioning. If Manual Lat/Lon is turned On, it overrides your GPS Lat/Lon position. Be sure Manual Lat/Lon and time of day are correctly entered before turning the function On. Time of day is entered as your local time in either 12 hour or 24 hour format. It is important that your local time offset from Universal Coordinated Time (UTC) is set correctly. See the **TIME SET** topic on the Main Menu.

To set Manual Lat/Lon:

- Press and hold the **CALL** key. Menu topics appear in the display.
- Use the **SELECT/ENT** knob to position the cursor on the **DATA SET** topic.
- Push the **SELECT/ENT** knob. The Data Set menu selections appear in the display.

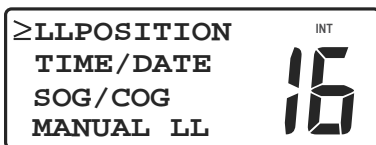

Data Set Selections

- Use the **SELECT/ENT** knob or  or  to select **MANUAL LL**.
- Push the **SELECT/ENT** knob. The **MANUAL LL** menu appears in the display.

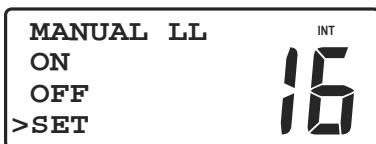



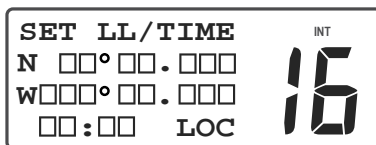

Manual LL Menu





- Use the **SELECT/ENT** knob to select **SET** on the menu.
- Push the **SELECT/ENT** knob. The **SET LL/TIME** screen appears.



Manual LL Entry

- Push the **SELECT/ENT** knob or  key to place the blinking cursor on the first character (**N** or **S**) in the Latitude entry line.
- Use the  key to toggle **N** or **S** to select a hemisphere (North or South) designator.
- Push **SELECT/ENT** knob or  to move the blinking cursor to the next character in the Latitude entry.
- Use the **SELECT/ENT** knob or the microphone keys 0~9 to enter the correct Latitude value in degrees, minutes and seconds. When Latitude is complete, the cursor moves to the Longitude line.
- Press the **SELECT/ENT** knob or  key to place the blinking cursor on the first

character (**E** or **W**) in the Longitude entry line.

- Use the  key to toggle **E** or **W** to select a hemisphere (East or West) designator.
- Push the **SELECT/ENT** knob or  to move the blinking cursor to the next character in the Longitude entry.
- Use the **SELECT/ENT** knob or the microphone keys 0~9 to enter the correct Longitude value in degrees, minutes and seconds. When Longitude is complete, the cursor moves to the Time entry line.
- Push the **SELECT/ENT** knob or  to move the blinking cursor to the first character in the Time entry.
- Use the **SELECT/ENT** knob or the microphone keys 0~9 to enter the correct time of day. **LOC** appears at the end of the Time line indicating entry must be local time.
- Enter your local time in hours and minutes. Use 12 hour AM/PM format if **a** or **p** appear after the minutes characters. The **SELECT/ENT** knob or the microphone keys 0~9 toggle the **a/p** setting. If neither **a** or **p** appear in the Time line, enter your local time, hours and minutes, in 24 hour format.
- When Lat/Lon and Time values are correct, press and hold the  key to return to the **MANUAL LL** menu page.

To turn Manual Lat/Lon On or Off:

- Use the **SELECT/ENT** knob to select either On or Off on the **MANUAL LL** page.
- Push the **SELECT/ENT** knob to store the selection.
- Press the  key. The Main display appears. If Manual Lat/Lon is turned On, and manually entered values are stored, the Lat/Lon values appear in the lower two lines of the display. The **M** appearing at the end of the Longitude line indicates that Manual Lat/Lon is turned On. When Manual Lat/Lon is turned On, the manually entered position overrides any Lat/Lon position from a navigation receiver.

MMSID SET

Provides for entry of the 9 digit MMSI for your vessel which must be entered in order to make DSC calls. MMSI must be obtained from government communication authorities or authorized agents.

CAUTION NOTE

Only one entry attempt is permitted. A warning is displayed after the first attempt and MMSID entry is blocked. **CALL YOUR DEALER FOR ASSISTANCE.**

To enter your MMSI number:

- Press and hold the  key. Menu topics appear in the display.
- Use the **SELECT/ENT** knob to position the cursor on the **MMSID SET** topic.
- Push the **SELECT/ENT** knob. The **MMSID TYPE** menu appears in the display.

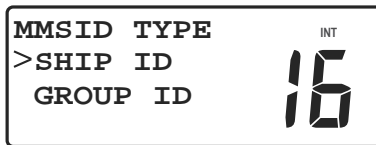

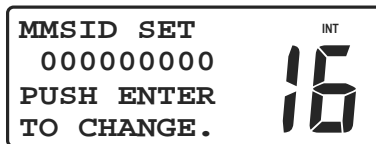

MMSID Type Select

- Use the **SELECT/ENT** knob to select **SHIP ID** on the menu.
- Push the **SELECT/ENT** knob. The **MMSID SET** screen appears in the display.



MMSID Set Screen

- Push the **SELECT/ENT** knob. The blinking cursor appears at the first digit position.
- Use the **SELECT/ENT** knob or the microphone keys 0~9 to enter your official MMSI number.
- When the last digit is selected, push the **SELECT/ENT** knob or  key.
- Push the **SELECT/ENT** knob or  key again. **STORED OK** appears briefly in

the lower line of the display completing the entry.

- Press the **16** key to return to the Main display.

Follow the above procedure to enter your Group ID number. Group ID entry attempts are not limited in number.

ATIS SET

See the **9.1 ATIS SET** topic of **9. ATIS OPERATION** section.

TIME SET

Allows selection of either 12 or 24 hour time format and provides entry of local time offset from Universal Coordinated Time (UTC), sometimes called Greenwich Mean Time (GMT). UTC is the time at the Prime Meridian, or zero degrees (0°) Longitude which passes through Greenwich, England.

- Press and hold the **CALL** key. Menu topics appear in the display.
- Use the **SELECT/ENT** knob to position the cursor on the **TIME SET** topic.
- Push the **SELECT/ENT** knob. The **TIME FORMAT** menu appears in the display.

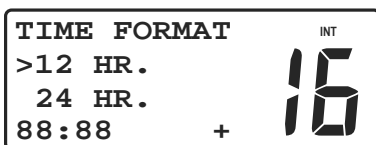

Format Selection

- Use the **SELECT/ENT** knob to select the desired format, either **12 HR** or **24 HR**.
- Push the **SELECT/ENT** knob. The **TIME OFFSET** menu appears in the display.

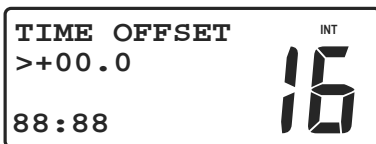

Time Offset Selection

- Use the **SELECT/ENT** knob to set the time difference from the Prime Meridian to your location. If you are West of the Prime Meridian, select a negative (-) value. If you are East of the Prime Meridian, select a positive (+) value. Time offset values from 0 to 12 hours plus or minus may be entered in 1/2 hour increments. Obtain the time offset value from your GPS navigator.

- When your selection is complete, push the **SELECT/ENT** knob to store the setting and exit the menu.

NMEA SET

Allows NMEA sentences from navigation equipment manufactured to earlier versions of the NMEA standard to provide Lat/Lon position coordinates and UTC time.

- Press and hold the **CALL** key. Menu topics appear in the display.
- Use the **SELECT/ENT** knob to position the cursor on the **NMEA SET** topic.
- Push the **SELECT/ENT** knob. The **NMEA CHECKSUM** menu appears in the display.



NMEA Checksum Selection

- Use the **SELECT/ENT** knob to select either **ON** or **OFF**.
- When your selection is complete, push the **SELECT/ENT** knob to store the setting and exit the menu.

GPS ALERT

Provides ON/Off settings for GPS Alert. It is usually set to On. If data from your GPS navigation receiver is lost, 3 quick error beeps are sounded and ****GPS OFF** is displayed on the second line of the Normal Communication screen, alternately with the date & time and channel name (alternately with **MEM CHANNEL** and channel name, in case that displayed channel is memory channel). Press the **16** or **END**

key to silence the 3 quick error beeps.

To set the GPS Alert:

- Press and hold the **CALL** key. Menu topics appear in the display.
- Rotate the **SELECT/ENT** knob to position the cursor on the **GPS ALERT** topic.
- Push the **SELECT/ENT** knob. The **GPS ALERT** menu appears in the display.

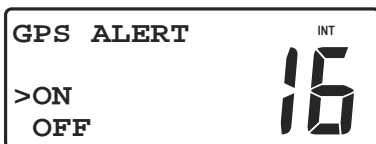

GPS Alert menu

- Rotate the **SELECT/ENT** knob to select **ON** or **OFF**.
- Push the **SELECT/ENT** knob to store the setting and exit the menu.

NOTE

Irrespective of this setting, 4 hours and 23.5 hours alert timer is effective. See the **8. DSC OPERATION** section.

CH NAME

Each channel is displayed with default channel name on the second line of the Normal Communication screen, alternately with the date & time (alternately with **MEM CHANNEL**, in case that channel is memory channel). You can edit these channel names as you like.





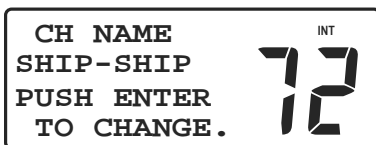

To edit the channel names:

- Select the channel which you want to edit the channel name.
- Press and hold the  key. Menu topics appear in the display.
- Use the **SELECT/ENT** knob to position the cursor on the **CH NAME** topic.
- Push the **SELECT/ENT** knob. The **CH NAME** screen appears in the display.



CH Name Screen

- Push the **SELECT/ENT** knob. The underline cursor appears at the first character position.
- Use the **SELECT/ENT** knob to move the underline cursor to the character position needing change.
- Push the **SELECT/ENT** knob or  key. The blinking cursor appears.

- Use the **SELECT/ENT** knob or microphone keys to change the contents of the character to the new value.
- When the new value is correct, push the **SELECT/ENT** knob or  key.
- Up to eleven characters are allowed in the channel name. If more characters need changing, push the **SELECT/ENT** knob or  or  key to move the cursor to the next desired character. If no more changes are desired, push the **SELECT/ENT** knob or  key to advance the cursor to the last character.
- When the last character is selected, push the **SELECT/ENT** knob or  key.
- **STORED OK** appears briefly in the lower line of the display completing the entry.
- Press the  key to return to the Main display.

FOG FREQ.

Allows selection of tone frequency for Fog Horn operation. Tone frequency is available to select within the range from 250Hz to 750Hz in 50Hz spacing. The default tone frequency is 450Hz.

- Press and hold the  key. Menu topics appear in the display.
- Rotate the **SELECT/ENT** knob to position the cursor on the **FOG FREQ.** topic.
- Push the **SELECT/ENT** knob. The **FOG FREQ.** screen appears in the display.



Fog Freq. Selection

- Rotate the **SELECT/ENT** knob to select the desired frequency.
- Push the **SELECT/ENT** knob to store the setting and exit the menu.

MIC LOCK

In order to prevent accidental channel change, all microphone keys except **PTT** may be locked. In **MIC LOCK** mode, an error beep sounds even if any microphone key

except **PTT** is pressed.

- Press and hold the **SELECT/ENT** knob. **MIC LOCK** annunciator appears in the display.

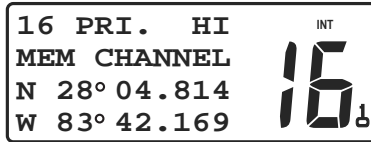

Mic Key Lock annunciator

To unlock the microphone keys:

- Press and hold the **SELECT/ENT** knob until **MIC LOCK** annunciator is gone.

CH CHANGE (Automatic CH Change)

For incoming Distress Call, All Ship's Distress or Urgency Call, you can select whether your radio automatically switches to Channel 16 or you determine to manually accept or decline the channel change.

- Press and hold the  key. Menu topics appear in the display.
- Rotate the **SELECT/ENT** knob to position the cursor on the **CH CHANGE** topic.
- Push the **SELECT/ENT** knob. The **AUTO CH CHANGE** menu appears in the display.



Auto CH Change menu

- Rotate the **SELECT/ENT** knob to select **ON** or **OFF** (default is **ON**).
- Push the **SELECT/ENT** knob to store the setting.

7. PA/FOG/INTERCOM OPERATION

PA Hail, Fog Horn and Intercom operations are available on your *MT-700* transceiver. For PA Hail and Fog Horn operations, you need to purchase and connect an extra PA Speaker (30W nominal at 13.6V/4Ohm). Intercom operation needs to install the optional *MT-RM01* Remote Microphone.

7.1 PA Hail

PA Hail operation provides a listen-back feature which allows the two-way communication through the PA Speaker.

To enable the PA Hail operation:

- Press the  key. The **PA/FOG** menu appears in the display.



PA/FOG Menu Topics

- Push the **SELECT/ENT** knob. The **PA** screen (**LISTEN** mode) appears in the display.



PA Screen (LISTEN)

- Press the **PTT** button to switch to the **HAIL** mode. You can speak through the PA hailer speaker. Use the **SELECT/ENT** knob to adjust the volume level.



PA Screen (HAIL)

- Release the **PTT** button to return to the **LISTEN** mode. To adjust the volume level on *MT-700*, rotate the **PWR/VOL** knob (To adjust the volume level on

MT-RM01, use the **SELECT/ENT** dial after pressing the **(VOL)** key).

- The **(END)** key may be used to exit the PA mode and return to the Normal Communication screen.

NOTE

While the PA Hail mode is active, you will receive on the last selected channel, and receive DSC calls. Transmitting on the last selected channel will not operate.

7.2 Fog Horn

Fog Horn operation allows your MT-700 transceiver to emit a various warning signals through the PA Speaker when the visibility is bad. You can select from the following 4 automatic and 2 manual patterns:

Automatic	UNDERWAY:	Motor vessel underway and making way.
	STOP:	Motor vessel underway but stopped (not making way).
	SAIL:	Sailing vessel underway, fishing vessel (underway or anchored), vessel not under command, a vessel restricted in her ability to maneuver (underway or at anchor), or a vessel towing or pushing another ahead.
	TOW:	Vessel under tow (manned).
Manual	HORN:	Signal for passing.
	SIREN:	Yelp type emergency siren.

To enable the Fog Horn operation:

- Press the **(PA FOG)** key. **PA/FOG** Menu topics appear in the display.
- Rotate the **SELECT/ENT** knob to position the cursor on the **FOG** topic.
- Push the **SELECT/ENT** knob. The Fog Horn selections appear in the display.



Fog Horn Selections

- Rotate the **SELECT/ENT** knob to select the desired Fog Horn pattern.
- Push the **SELECT/ENT** knob.

Automatic : When you select the **UNDERWAY**, **STOP**, **SAIL** or **TOW** modes, a peculiar pattern is automatically emitted. Use the **SELECT/ENT** knob to adjust the volume level.

Manual : When you select the **HORN** or **SIREN** modes, press the **PTT** button. A continuous tone is emitted while the **PTT** button is pressed. Use the **SELECT/ENT** knob to adjust the volume level.



UNDERWAY Emitted

- The **END** key may be used to exit the Fog Horn mode and return to the Normal Communication screen.

NOTE

While the Fog Horn mode is active, you will receive on the last selected channel, and receive DSC calls. Transmitting on the last selected channel will not operate.

7.3 Intercom

When the optional *MT-RM01* Remote Mic is installed, you can make a voice communication between your *MT-700* transceiver and *MT-RM01* Remote Mic.

To enable the Intercom operation:

- Press and hold the **PA-FOG** key on *MT-700* (Press and hold the **PA-FOG** key on *MT-RM01*). The **INTERCOM** screen appears in the display. Calling beep tone is heard on the receiver station, which will be cancelled when the **PTT** button is pressed.

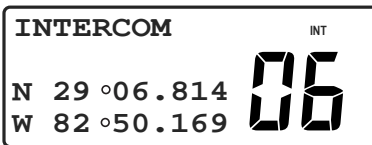

MT-700



MT-RM01

- Press the **PTT** button. Speak into the microphone.
- When finish speaking, release the **PTT** button and listen for a reply.

- To adjust the speaker output level on *MT-700*, rotate the **PWR/VOL** knob (To adjust the speaker output level on *MT-RM01*, use the **SELECT/ENT** dial after pressing the **VOL** key).
- The **END** key on *MT-700* (The **END** key on *MT-RM01*) may be used to exit the Intercom mode and return to the Normal Communication screen.

NOTE

While the Intercom mode is active, you will receive on the last selected channel, and receive DSC calls. Transmitting on the last selected channel will not operate.

8. DSC OPERATION

The Digital Selective Calling (DSC) functions of your *MT-700* transceiver add convenience and safety to your VHF communication capability. DSC allows you to contact other DSC equipped vessels and shore stations by selecting their names from your personal call directory, choosing a call type, and pressing a key. In an emergency, pressing one button will send your vessel ID and current position to search and rescue (SAR) authorities and other DSC equipped vessels. Distress calls are covered first. Then, normal calling procedures are described.

Position reporting requires connection to an operating GPS navigation receiver or manually entered Lat/Lon coordinates. If data from your GPS is lost, 3 quick error beeps are sounded and the following warning screen appears in the display every 4 hours.



Set Manual Lat/Lon

This warning screen reminds you to manually enter Lat/Lon coordinates. See the **MANUAL LL** item of the **DATA SET** topic of the **6.7 Main Menu Topics**. If Lat/Lon coordinates are entered manually but have not been updated for 23.5 hours, the position fields are set to the repeated "9" and time field is set to the repeated "8".

8.1 MMSID

SPECIAL NOTE

In order to use DSC functions, you must obtain a nine-digit maritime mobile service identity (MMSI) and program it into your transceiver before you transmit.

Prior to obtaining an MMSI, you will be asked to provide certain information about your vessel and communication equipment. Contact the government radio communication authorities of your country for licensing and MMSI information. It is important that you obtain an MMSI, because National Coast Guard authorities use this information to help speed search and rescue operations.

The procedure for entering your MMSI is described in the **MMSID SET** topic of the **6.7 Main Menu Topics**.

8.2 Sending a Distress Call

To make a Distress Call:

- Lift the red protective cover, then press and release the red button. The distress alert screen appears.



Distress Alert Screen

- If time permits, use the **SELECT/ENT** knob to select the nature of distress.

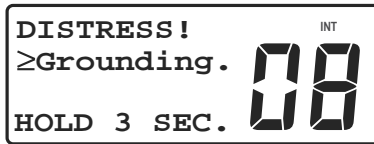

Select the Nature of Distress

Nature of Distress		
Undesignated.	Fire or Explosion.	Flooding.
Collision.	Grounding.	Listing or Capsizing.
Sinking.	Disabled & Adrift.	Abandoning Ship.
Piracy Attack.	Man Overboard.	

- Hold the red button (as soon as the button is pressed again, an intermittent acoustic alarm is sounded and the distress alert screen flashes until the **DISTRESS** is sent automatically, in about 3 seconds). Before the distress is sent, you may release the red button to reset the countdown timer.
- An alarm sounds and the following screen appears as your distress message is being transmitted.

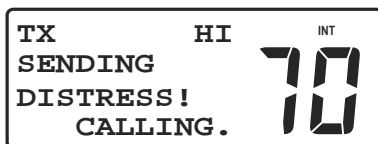

Sending Distress Call

- The following screen appears indicating your distress message has been transmitted.

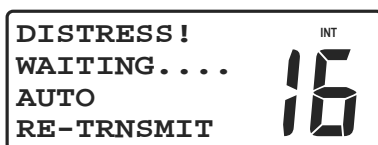

Distress Call Sent

The DSC distress message is automatically sent on channel 70 and your transceiver is automatically set to Channel 16 in order to listen for, and respond to, voice replies from SAR authorities or other vessels which may have received your distress call. The alarm will sound every 15 seconds to remind you that a distress message is active. Unless canceled, the distress message is automatically re-transmitted every 3 1/2 to 4 1/2 minutes.

Re-transmissions of DSC distress calls are canceled automatically when a DSC acknowledgment is received from an authorized SAR coast station, or canceled manually by you.

To cancel the Automatic Re-transmission of Distress Call:

- Press the  key. The alarm is stopped, and the Automatic Re-transmission of Distress Call is cancelled. It does not interrupt the transmission of Distress Call already in progress. Display reverts to the following screen with the previously selected nature of distress, and you can attempt to transmit the Distress Call again at any time.

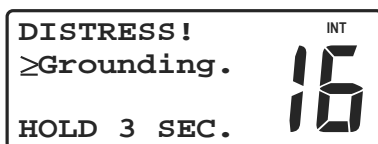

Auto Re-transmission cancelled

To manually cancel a Distress Call:

- Press the **END** key again. The **DISTRESS CANCELED** message appears in the display.

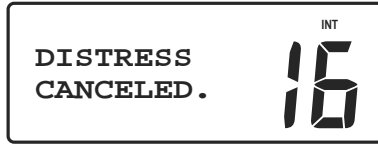

Manual Distress Cancel

If your Distress Call is acknowledged (ACK) by a coast station:

- The **DISTRESS! CANCELED. ACK RECEIVE** screen appears in the display.

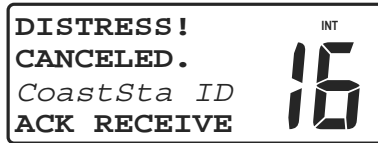

Distress Acknowledged

- Establish voice contact with the coast station on Channel 16.

8.3 Receiving Distress Calls

Your *MT-700* transceiver may intercept distress messages sent by another vessel and/or acknowledgments (ACK) sent by a coast station to another vessel in distress. In such cases you should maintain a listening watch on channel 16 and standby to lend assistance. Your *MT-700* does not automatically reply to, or relay, distress or ACK or relay DSC calls.

Distress sent by another vessel

If your *MT-700* transceiver intercepts a distress call from another vessel, an alarm sounds and the screen presents time of distress, MMSID of the distressed vessel, and Lat/Lon coordinates. The plus sign (+) indicates there is another page of information available. If invalid GPS or Time data is received, the Lat/Lon position shows "9" in all digits and the time shows all "8"s.

To accept a Distress Call when Auto CH Change is ON (default):

- Your transceiver is automatically set to Channel 16.

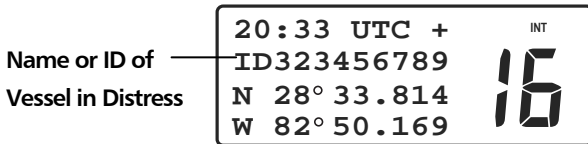

Distress Alert, page 1

- Push the **SELECT/ENT** knob to mute the alert and toggle between page 1 and page 2. The nature of distress and ALERT call type appear on the second page.

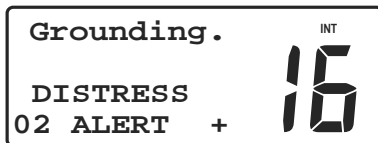

Distress Alert, page 2

To accept a Distress Call when Auto CH Change is OFF:

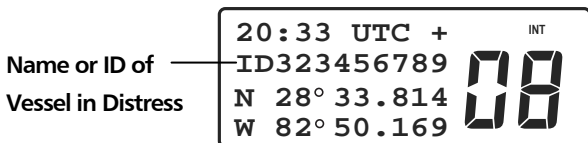

Distress Alert, page 1

- Push the **SELECT/ENT** knob. The alert is muted, and your transceiver is set to Channel 16.

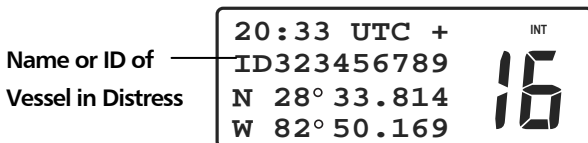

Set to Channel 16

- Push the **SELECT/ENT** knob to toggle between page 1 and page 2. The nature of distress and ALERT call type appear on the second page.

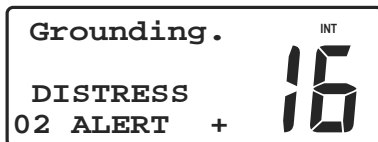

Distress Alert, page 2

Distress ACK sent to another vessel

If your *MT-700* transceiver intercepts a distress ACK from a coast station, an alarm sounds and the following screen appears in the display.

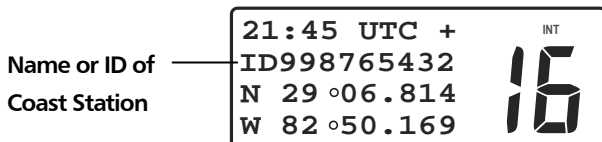

Coast Station ACK to other vessel, page 1

The screen presents time of ACK and Lat/Lon coordinates. The plus sign (+) indicates there is another page of information available.

- Push the **SELECT/ENT** knob to toggle between page 1 and page 2.

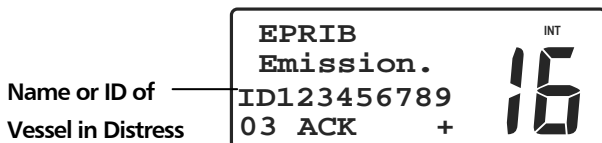

Coast Station ACK to other vessel, page 2

The distressed vessel's MMSID and **ACK** appear on the second page. Maintain a listening watch on channel 16 and standby to lend assistance.

Distress Relay from another vessel

If your *MT-700* transceiver intercepts a distress relay from another vessel, an alarm sounds and the following screen appears in the display.

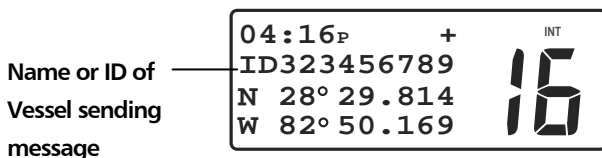

Distress Relay, page 1

The screen displays, local time of distress, the MMSID of the vessel sending the relay message and Lat/Lon coordinates of the vessel in distress. The plus sign (+) indicates there is another page of information available.

- Push the **SELECT/ENT** knob to toggle between page 1 and page 2.

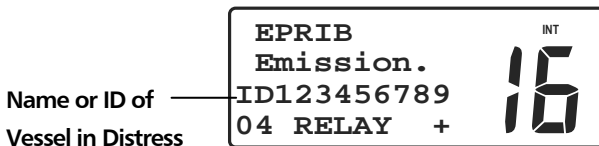

Distress Relay, page 2

The distressed vessel’s MMSID and **RELAY** call type appear on the second page.

Your vessel does not re-send a distress relay message.

8.4 Normal DSC Calls

Your *MT-700* can transmit the types of DSC calls; Distress, All Ship’s, Individual, and Group. Except for Distress, each call type is subdivided into one or more priorities.

All Ship’s type transmits two priorities: Urgency and Safety.

Individual type transmits one priority: Routine.

Group type transmits one priority: Routine.

Also *MT-700* can transmit the calls of advanced Individual Routine priority; Position Send, and Position Request. Lat/Lon position from another vessel can be transferred to the DSC equipped chart plotter, if it is connected.

A normal DSC call may be originated from your vessel to another DSC equipped vessel or to a coast station, or you may reply to a DSC call sent by another vessel or a coast station. Outgoing calls are made either by selecting a vessel or station name from your directory or by manually entering the vessel or station MMSID number (Position Send and Position Request are made from your directory only).

Replies to any incoming call type can be made directly from the call log. The call log (LAST CALL) holds thirty two entries and the last call received is on top of the list. If the call log is full, the oldest entry is lost.

Individual DSC Call

Individual calls can be made to another vessel or to a coast station. It is important to be able to differentiate between the two. When calling another vessel, the communication channel is specified in the call by the calling vessel. If communicating with a coast station, it is the coast station in its acknowledgment that determines the channel. Your *MT-700* transceiver transmits Routine individual calls, but receives both Routine and Safety individual calls.

- Directory Call

Directory calls are made by selecting a vessel or station name from the calling

directory. The calling directory holds thirty two of your previously entered names that you routinely contact during normal boating activities.

To make a directory call:

- Press the **CALL** key. The DSC calling menu appears in the display with the cursor indicating **INDIVIDUAL** topic.

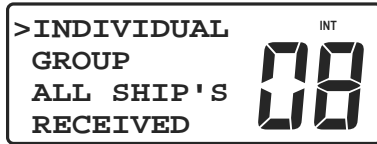

DSC Individual

- Push the **SELECT/ENT** knob or press the **CALL** key. The **INDIVIDUAL** menu appears in the display.
- Use the **SELECT/ENT** knob to select the **DIRECTORY** topic.



Individual Menu

- Push the **SELECT/ENT** knob or press the **CALL** key. The directory list appears in the display.
- Use the **SELECT/ENT** knob to select the desired vessel or station name.
Note: The MMSID's for each entry do not appear in the list.
- Press the **CALL** key. The **INDIVIDUAL** call screen appears in the display.
- Use the microphone keys to select a working channel.

NOTE

- 1) If you operate from *MT-RM01* Remote Mic, please select a working channel by the **SELECT/ENT** dial on the Normal Communication screen (before entering the DSC calling menu), because there is no numeric keys on the Remote Mic.
- 2) If the call is to the coast station, you should not select a working channel. Even if

you select, *MT-700* ignores it when transmits the call.

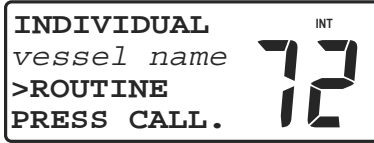

INDIVIDUAL
vessel name
>ROUTINE
PRESS CALL.

INT
72

Individual Call Screen

- Press the **CALL** key to send the call. DSC calls are made on channel 70. If you observe the display closely, you will see the channel number change to channel 70 momentarily and then revert to the original working channel.
- While waiting for acknowledgment from the called vessel, **WAITING** appears in the lower line of the display.

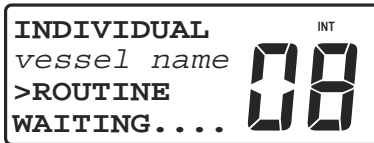

INDIVIDUAL
vessel name
>ROUTINE
WAITING

INT
00

Waiting For Acknowledge

- When the called vessel acknowledges your call, an alert sounds and **ACK RECEIVE** appears in the lower line of the display.

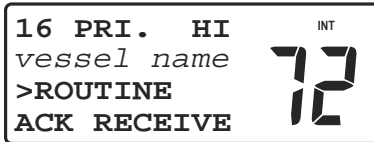

16 PRI. HI
vessel name
>ROUTINE
ACK RECEIVE

INT
72

Acknowledge Received

NOTE

If call is to a vessel, channel automatically switches to a selected working channel.

If call is to the coast station, channel automatically switches to a channel which coast station defined.

- Press the **PIT** button on the microphone to silence the alert and begin voice communication with the called vessel.
- The **END** key may be used to exit the DSC calling procedure at any time prior to sending the call.

- Manual Call

The manual call procedure is used to make a DSC call to a vessel or station that is not listed in your calling directory. However, you must know the MMSID for the vessel or station.

To make a manual DSC call:

- Press the **CALL** key. The DSC calling menu appears in the display with the cursor indicating **INDIVIDUAL** topic.

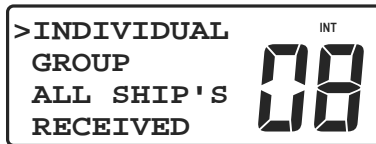

DSC Individual

- Push the **SELECT/ENT** knob or press the **CALL** key. The **INDIVIDUAL** menu appears in the display.
- Use the **SELECT/ENT** knob to select the **MANUAL** topic.



Individual Menu

- Push the **SELECT/ENT** knob or press the **CALL** key. The **SET Channel/SET MMSID** screen appears in the display.
- Use the **SELECT/ENT** knob or microphone keys to select a working channel. Four channel numbers appear in the display as suggested channels authorized for the call to vessel. Other channels may be used if authorized in your area.

NOTE

If the call is to the coast station, you should not select a working channel. Even if you select, *MT-700* ignores it when transmits the call.

- Push the **SELECT/ENT** knob. The blinking cursor moves to the first digit in the MMSID entry field. If the last used manual MMSID is displayed, push the **SELECT/ENT** knob once again.

- Use the **SELECT/ENT** knob or microphone keys to change the MMSID for the vessel or station to call.

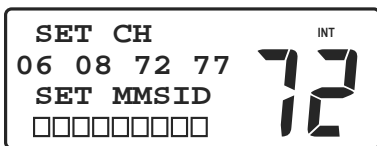

Set Channel/Set MMSID

- When the MMSID is correct, press the **CALL** key to send the call. DSC calls are made on channel 70. If you observe the display closely, you will see the channel number change to channel 70 momentarily and then revert to the original working channel.
- While waiting for acknowledgment from the called vessel or station, **WAITING . . .** appears in the lower line of the display.

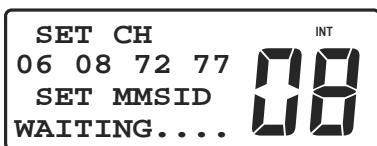

Waiting For Acknowledge

- When the called vessel or station acknowledges your call, an alert sounds and **ACK RECEIVE** appears in the lower line of the display.

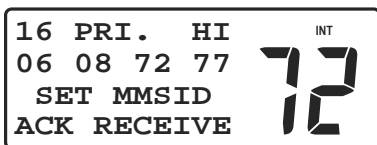

Acknowledge Received

NOTE

If call is to a vessel, channel automatically switches to a selected working channel.

If call is to the coast station, channel automatically switches to a channel which coast station defined.

- Press the **PTT** button on the microphone to silence the alert and begin voice communication with the called vessel or station.
- The **END** key may be used to exit the DSC calling procedure at any time prior

to sending the call.

All Ship's Call

The All Ship's call allows you to send an Urgent or Safety DSC call to nearby vessels without having to know their MMSID numbers. The All Ship's call may be used in situations that are serious but do not warrant a distress call, and voice communication attempts have failed.

To send an All Ship's call:

- Press the **CALL** key. The call menu appears in the display.
- Use the **SELECT/ENT** knob to select the **ALL SHIP'S** topic.



DSC All Ship's Call

- Push the **SELECT/ENT** knob or press the **CALL** key. The **CALL TYPE** menu appears in the display.



DSC Call Type

- Use the **SELECT/ENT** knob to select either **URGENT** or **SAFETY**.
- Press the **CALL** key. The Call Type Verification screen appears in the display.



Call Type Verification

- Call type must be verified.

- Press the **CALL** key to send the call. The **ALL SHIP'S WAITING** screen appears in the display. Either **URGENT** or **SAFETY** appear to indicate priority of the call.



Waiting For Voice Reply

- Your transceiver is automatically set to Channel 16. Listen for voice replies from vessels which have received your call. There is no DSC ACK reply to confirm that your call was received.
- Use the **PTT** button to continue voice communication. The Normal Communication screen appears in the display.
- If there is no response to your call, press the **END** key. The Normal Communication screen appears in the display.

Group Call

Your can arrange with other vessels to use a group MMSID so that any vessel in a group can contact all other vessels in the same group with a single DSC call.

Your group MMSID is stored in the same manner as your ship MMSID. Only one group MMSID is stored at a time, but group MMSID's can be changed as often as desired, allowing participation in more than one group.

To send a DSC group call:

- Press the **CALL** key. The call menu appears in the display.
- Use the **SELECT/ENT** knob to select the **GROUP CALL** topic.

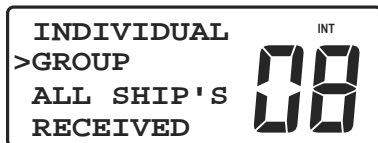

DSC Group Call

- Push the **SELECT/ENT** knob or press the **CALL** key. The **SET Channel** menu

appears in the display. The current group MMSID appears in the lower line of the display.

- Use the **SELECT/ENT** knob or the microphone keys to select a working channel. Four channel numbers appear in the display as suggested channels authorized for this type of call. Other channels may be used if authorized in your area.

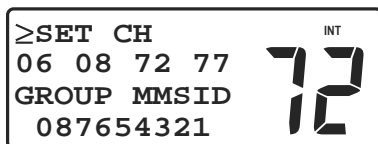

Set Channel

- Press the **CALL** key. The call is sent and **WAITING . . .** appears in the lower line of the display.
- Your transceiver is automatically set to the previously set working channel. Listen for voice replies from vessels which have received your call. There is no DSC ACK reply to confirm that your call was received.
- Use the **PTT** button to continue voice communication. The Normal Communication screen appears in the display.
- If there is no response to your call, press the **END** key. The Normal Communication screen appears in the display.

Position Send

Position Send can send your Lat/Lon position to another vessel that is listed in your calling directory.

To make a Position Send:

- Press the **CALL** key. The DSC calling menu appears in the display with the cursor indicating **INDIVIDUAL** topic.
- Push the **SELECT/ENT** knob or press the **CALL** key. The **INDIVIDUAL** menu appears in the display.
- Use the **SELECT/ENT** knob to select the **DIRECTORY** topic.



DSC Directory

- Push the **SELECT/ENT** knob or press the **CALL** key. The directory list appears in the display.
- Use the **SELECT/ENT** knob to select the desired vessel name.
Note: The MMSID's for each entry do not appear in the list.
- Press the **CALL** key. The **INDIVIDUAL** call screen appears in the display.

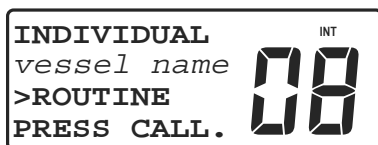

Individual Call Screen

- Use the **SELECT/ENT** knob to select **SEND POS**.

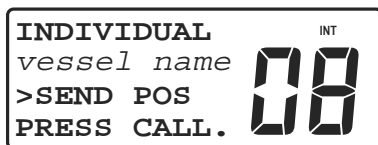

Position Send Screen

- Press the **CALL** key to send the call. Call is made on channel 70. If you observe the display closely, you will see the channel number change to channel 70 momentarily and then revert to the previous working channel.
- Press the **END** key to return to the Normal Communication screen.

Position Request

Position Request can request Lat/Lon position from another vessel that is listed in your calling directory.

To make a Position Request:

- Press the **CALL** key. The DSC calling menu appears in the display with the cursor indicating **INDIVIDUAL** topic.
- Push the **SELECT/ENT** knob or press the **CALL** key. The **INDIVIDUAL** menu appears in the display.
- Use the **SELECT/ENT** knob to select the **DIRECTORY** topic.



DSC Directory

- Push the **SELECT/ENT** knob or press the **CALL** key. The directory list appears in the display.
- Use the **SELECT/ENT** knob to select the desired vessel name.
Note: The MMSID's for each entry do not appear in the list.
- Press the **CALL** key. The **INDIVIDUAL** call screen appears in the display.

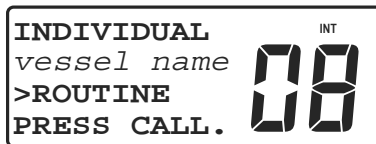

Individual Call Screen

- Use the **SELECT/ENT** knob to select **REQ POS**.

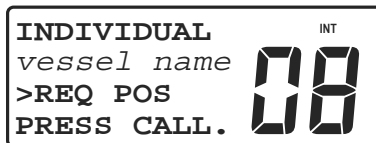

Position Request Screen

- Press the **CALL** key to send the call. Call is made on channel 70. If you

observe the display closely, you will see the channel number change to channel 70 momentarily and then revert to the previous working channel.

- While waiting for the reply from the called vessel, **WAITING** appears in the lower line of the display.

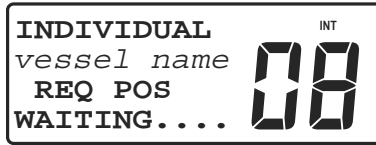

Waiting For the reply

- When the called vessel reply to your call, an alert sounds and **RECEIVED POSITION** appears in the display.

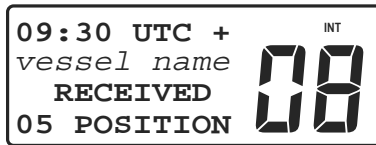

Position Received

- Push the **SELECT/ENT** knob to see the received Lat/Lon position.

8.5 Receiving DSC Calls

Your *MT-700* can receive four types of DSC calls; Distress, All Ship's, Individual, and Group. Except for Distress, each call type is subdivided into one or more priorities.

All Ship's type receives the following priorities: Distress ACK, Distress Relay, Urgency, and Safety.

Individual type receives the following priorities: Safety and Routine.

Group type receives one priority: Routine.

Also *MT-700* can receive the calls of advanced Individual Routine priority; Position Send, and Position Request. Lat/Lon position from another vessel can be transferred to the DSC equipped chart plotter, if it is connected.

When your *MT-700* receives a DSC call from another vessel or a coast station, an alert sounds and a Call Received screen appears in the display. The Call Received screen identifies the time of a call, the caller, the type and the priority of a call. Also, a number appears in the screen indicating the number of calls in the log. The call log holds thirty two entries.

Individual Call Received

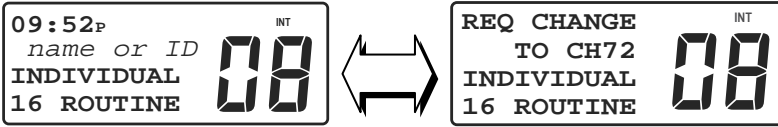

Individual Routine

If the calling vessel or station is listed in your DSC calling directory, the vessel or station name, as it is listed, appears in the display. If the caller is not listed in your directory, the caller's MMSID appears in the display. Also, alternating page shows the requested working channel by a caller.

To accept an Individual Call:

- Push the **SELECT/ENT** knob to confirm the requested working channel and mute the alert. ACK screen appears.

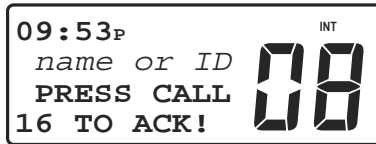

Routine ACK Screen

- Press the **CALL** key to acknowledge the call. ACK is made on Channel 70 and then your transceiver is set to the selected working channel by the caller. The caller should respond to your ACK with voice communication. If not, you may initiate voice communication.

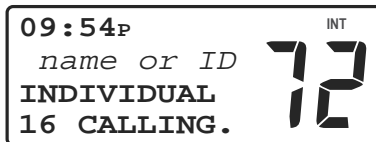

Routine ACK Screen

To decline an Individual Call:

- Press the **END** key. The call is interrupted and the Normal Communication screen appears in the display.

If caller requests an invalid working channel:

- **UNABLE TO COMPLY** acknowledgement is automatically sent and the following screen appears in the display.

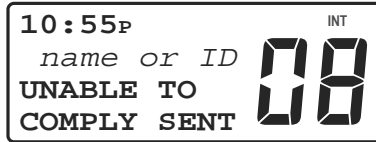

Unable to Comply ACK Screen

Last Call Received

Replies to incoming calls are made using the call log. The call log holds thirty two entries and the last call received is on top of the list. When the thirty third call is received, the oldest entry is lost. Making DSC calls from the call log is the like making calls from the DSC calling directory.

To instantly reply to the last call received or any log entry:

- Press the **CALL** key. The DSC calling menu appears in the display.
- Use the **SELECT/ENT** knob to select the **RECEIVED** topic on the menu.



DSC Call Menu

- Push the **SELECT/ENT** knob or Press the **CALL** key. The most recent call in the call log appears in the screen.

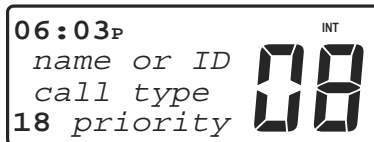

Last Call

- Observe the type and priority of the last call logged.
- Use the **SELECT/ENT** knob to select the entry to call.

- Press the **CALL** key. An Individual Routine call is transmitted regardless of the type and priority of the last call logged.
- Proceed in the same manner as with normal DSC calls.

All Ship's Call Received

An All Ship's call is received from other vessels or coast stations within VHF range of the transmitter. All Ship's calls present Distress, Urgent or Safety information important to all vessels in the area.

- All Ship's Safety Call Received

When an All Ship's Safety call is received, an alert sounds and the following screen appears in the display.



All Ship's Safety

If the calling vessel or station is listed in your DSC calling directory, the vessel or station name, as it is listed, appears in the display. If the caller is not listed in your directory, the caller's MMSID appears in the display.

To accept an All Ship's Safety Call:

- Push the **SELECT/ENT** knob. The alert is muted and your transceiver is set to Channel 16.

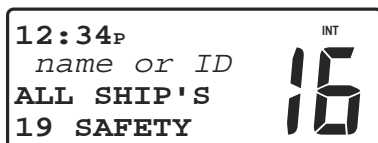

All Ship's Safety (Channel changed)

- Press the **PTT** button to communicate on Channel 16. There is no DSC ACK for All Ship's calls.

To decline an All Ship's Call:

- Press the **END** key. The call is interrupted and the Normal Communication screen appears in the display.

- All Ship's Distress or Urgency Call Received

For incoming All Ship's Distress or Urgency call, replying procedure depends on the Auto CH Change setting. If setting is ON (default), your transceiver is automatically set to Channel 16. If setting is OFF, you determine to manually accept the channel change or decline the call.

To accept an All Ship's Distress or Urgency Call when Auto CH Change is ON (default):

- Your transceiver is automatically set to Channel 16.

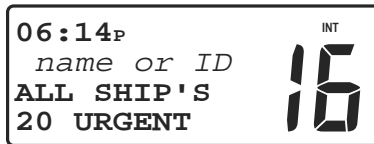

All Ship's Urgent (when Auto CH Change is ON)

- Push the **SELECT/ENT** knob to mute the alert, if you need.
- Press the **PTT** button to communicate on Channel 16.

To accept an All Ship's Distress or Urgency Call when Auto CH Change is OFF:

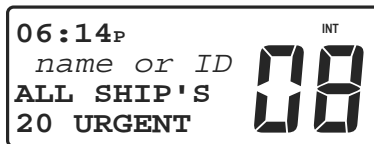

All Ship's Urgent (when Auto CH Change is OFF)

- Push the **SELECT/ENT** knob. The alert is muted and your transceiver is set to Channel 16.



All Ship's Urgent (Channel changed)

- Press the **PTT** button to communicate on Channel 16.

To decline an All Ship's Call:

- Press the **END** key. The call is interrupted and the Normal Communication screen appears in the display.

Group Call Received

A group call is received when anyone in your prearranged group makes a group call.

To accept a Group Call:

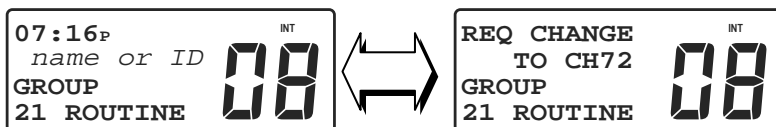

Group Call

- Push the **SELECT/ENT** knob. The alert is muted and your transceiver is set to the selected working channel by the caller.

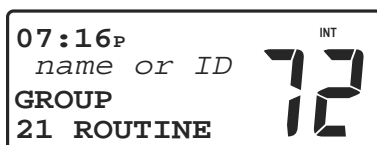

Group Call (Channel changed)

- Press the **PTT** button to answer the call with voice communication on the working channel selected by the caller. There is no DSC ACK for Group Calls.

To decline a Group Call:

- Press the  key. The call is interrupted and the Normal Communication screen appears in the display.

Position Send Received



Position Received

When you receive the position send from another vessel, an alert sounds and **RECEIVED POSITION** appears in the display.

If the calling vessel is listed in your DSC calling directory, the vessel name, as it is listed, appears in the display. If the caller is not listed in your directory, the caller's MMSID appears in the display.

- Push the **SELECT/ENT** knob to see the received Lat/Lon position.

Position Request Received

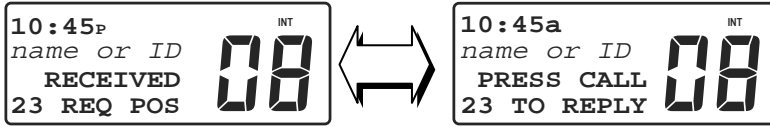

Call Received screen

Reply screen

If the calling vessel is listed in your DSC calling directory, the vessel name, as it is listed, appears in the display. If the caller is not listed in your directory, the caller's MMSID appears in the display. Also the Reply screen alternates with the Call Received screen.

To reply to a Position Request:

- Press the **CALL** key to send your position.
- Press the **END** key to return to the Normal Communication screen.

To decline a Position Request:

- Press the **END** key. The call is interrupted and the Normal Communication screen appears in the display.

To silence the alert and reply later:

- Push the **SELECT/ENT** knob. The Reply screen continues to alternate with the Call Received screen in the display.

9. ATIS OPERATION

Your *MT-700* can enable to operate ATIS (Automatic Transmitter Identification System) function if you are navigating on the inland waterways in Europe. ATIS function sends the data which identifies you at the end of the transmission. Also TX on channel 06, 08, 10, 11, 12, 13, 14, 15, 17, 71, 72, 74, 75, 76 and 77 is restricted to 1W.

9.1 ATIS SET

To enable ATIS function:

- Press and hold the  key. Menu topics appear in the display.
- Rotate the **SELECT/ENT** knob to position the cursor on the **ATIS SET** topic.
- Push the **SELECT/ENT** knob. The **ATIS SET** menu appears in the display.

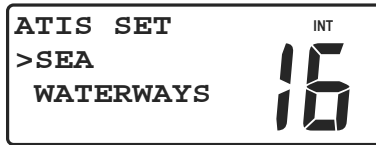

ATIS Set Menu

- Rotate the **SELECT/ENT** knob to select **WATERWAYS** to enable ATIS function and automatically disable DSC function.
- Push the **SELECT/ENT** knob to store the setting and exit the menu.

NOTE

When enable ATIS function;

Frequency bank annunciator (**INT**) disappears in the display. You can know that now you are in **WATERWAYS** mode.

DISTRESS, **CALL**, **SCAN** and **MEM** keys will not operate and a beep error tone is emitted when press them.

DIRECTORY, **DATA SET**, **MMSID SET** and **NMEA SET** will not be displayed in Menu topics.

9.2 ATIS ID

In order to use ATIS function, you must program 10 digits of numerical ATIS ID into the transceiver. This ATIS ID is derived from your ship call sign. If you are not sure how to derive 10 digits of numeral from your ship call sign, please ask your dealer.

CAUTION NOTE



Only one entry attempt is permitted. A warning is displayed after the first attempt and ATIS ID entry is blocked. CALL YOUR DEALER FOR ASSISTANCE.

To enter your ATIS ID:

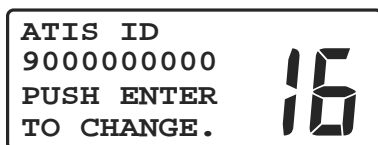
- Press and hold the  key. Menu topics appear in the display.
- Rotate the **SELECT/ENT** knob to position the cursor on the **ATIS ID** topic.
- Push the **SELECT/ENT** knob. The **ATIS ID** menu appears in the display.



ATIS ID Set Screen

- Push the **SELECT/ENT** knob. The cursor after "9" is blinking. The first numeral is always "9".
- Use the **SELECT/ENT** knob or microphone keys 0-9 to enter the rest of 9 numerals.
- When the last numeral is selected, push the **SELECT/ENT** knob or  key.
- Push the **SELECT/ENT** knob or  key again. **STORED OK** appears briefly in the lower line of the display completing the entry.
- Press the  key to return to the Main display.

NOTE

If you use the *MT-700* without entering ATIS ID, *MT-700* will not be changed to the transmit mode. In this situation, an error beep sounds even if press the PTT key of microphone. TX indication does not appear in the display.

10. REFERENCE

10.1 Maintenance

The *MT-700* VHF transceiver is produced with proven processes and current solid state technology. With reasonable care, your *MT-700* will have a long useful life.

The following precautions will prevent damage to the transceiver.

- Never press the PTT button unless an antenna or proper dummy load is connected to the antenna jack.
- Do not operate the transceiver if the power source is not within the specified range of 11 to 16 Vdc.
- Replace the antenna and/or coaxial cable if damaged in any way or severely weathered.
- Avoid continuous direct sunlight on the LCD.
- Avoid overextending the microphone cable.
- Do not use solvents or harsh chemicals to clean the microphone, casework or LCD display.

10.2 Special Functions

Clear Memory Channels

Clears the channel bank for the Memory Scan function.

- Press and hold the  key while turning power On.

New Microphone

Initializes the keypad when a new microphone is installed.

- Press and hold the  key on the microphone while turning power On.

Printer Operation

Initializes the Tx port for 4800 baud PC/printer interface.

- Press and hold the  key while turning power On.

10.3 Troubleshooting

Troubleshooting Chart		
Symptom	Probable Cause	Corrective Action
Transceiver won't turn On.	No dc voltage, blown fuse, faulty wiring.	Press and hold the PWR/VOL knob, check buss voltage, and replace fuse (6.3 Amp), check power cable and connections.
Buzzing sound from speaker with engine running.	Ignition or charging system noise.	Reroute dc power cable, install noise filter on alternator and dc power cable, use resistive spark plug wires.
No sound from speaker.	Squelch control set too high, volume control set too low.	Set SQ control full CCW, set PWR/VOL CW.
	Channel blocked by stuck mic button.	Select a different channel. Look for TX annunciator in display.
	Faulty external speaker or cable.	Unplug external speaker cable.
Reports of weak transmit signals even when using HI power settings.	Antenna.	Have a technician test transmitter output power and antenna VSWR.
	Coaxial cable faulty.	Inspect antenna cable carefully for nicks. Wet coax absorbs transmitter power.
Latitude and longitude coordinates are not displayed.	Lat/Lon position display not turned On.	Use Menu - Data Set - LL Position, to turn On.
	GPS cable faulty or disconnected.	Check cable and connections.
	GPS not operating or position is invalid.	Make sure GPS is functioning and output format is NMEA 0183 with GLL, GGA, RMC or GNS sentence selected.

10.4 Specifications

MT-700 Technical Specifications

GENERAL

Compliance:	Meets EU specification EN301-025 V1.3.1 (February 2007), Radio Regulations Appendix 18, and DSC Class D.
Number of Channels:	All available INT'L (per Appendix 18). Externally FLASH programmable for various Country Requirements.
Vdc Input:	13.6 Vdc.
Size (W x H x D):	177.2mm x 91.2mm x 226.8mm. Heat sink is included. Not bracket.
Weight:	1.8Kg with MIC.
Waterproofness:	JIS-7
Antenna:	50 OHM impedance with SO239 Connector. Transmitter operates 5 minutes into OPEN or SHORT.
Temperature Range:	-15 Degrees C to +55 Degrees C
Construction:	UV Stable Case with Backlighting silicon rubber keypad. Die Cast Rear Heat sink.
LCD Display:	4 Lines with 11 characters each and BOLD channel number display with 3 discrete annunciators. Silver background with dark Black letters and Bright Orange display backlighting. LCD has dimmable ORANGE display/keypad backlighting. Contrast control provides best viewing angle. Viewing area is 620mm x 230mm.
Speaker:	Sealed Water Resistant Polypropylene.
Microphone:	Special styled MIC with 12 Alpha Numeric keys. MIC editing works simultaneously with Code Wheel and allows discrete channel entry.
Channel/Selection Changing:	2 bit Code Wheel.

External Connections: Jack for External Speaker & 8 pin COM connector.

Watch Receiver: Separate CH70 watch receiver included. Decoding performance is less than 10^{-2} Bit error rate with 0dB μ V input signal level.

CPU: High-speed 8 bit RISC microprocessor with FLASH programmable.

DSC Call Types: See chart below:

Format Specifier	Category	First Telecommand Symbol number	Receive	Transmit
Distress - (112)		F3E/G3E Simplex - (100)	X	X
All Ship's - (116)	Distress - (112)	Distress ACK - (110)	X	
All Ship's - (116)	Distress - (112)	Distress RELAY - (112)	X	
All Ship's - (116)	Urgency - (110)	F3E/G3E Simplex - (100)	X	X
All Ship's - (116)	Safety - (108)	F3E/G3E Simplex - (100)	X	X
Individual - (120)	Urgency - (110)	F3E/G3E Simplex - (100)	X	
Individual - (120)	Safety - (108)	F3E/G3E Simplex - (100)	X	
Individual - (120)	Routine - (100)	F3E/G3E Simplex - (100)	X	X
Individual - (120)	Routine - (100)	Ship Position - (121)	X	X
Group - (114)	Routine - (100)	F3E/G3E Simplex - (100)	X	X
2 nd Telecommand Transmit & Receive (126) - No Information.				

DSC Distress Key: Red & Covered. Plastic Cover is hinged to prevent loss. Key is backlighted full time. Hold down 3 seconds-countdown timer is displayed.

DSC Call Log: 32 Entries. Instant call back any Log Entry with Individual Routine call.
 Caller's Name is displayed if MMSID matches to Directory Entry.

DSC Directory: 32 Entry list with scrolling and Auto Sorting. Entries can be edited to Line/Character position.

MMSID: Own Ship's & Group are stored in nonvolatile

	memory.
Memory Scan Channels:	Unlimited with instant editing and can be cleared on Power-up. The Memory Channel list is presented in a Page Mode format with instant ADD/DELETE function.
Alarm Tones:	3 different tone sequences are provided.
Frequency Control Method:	Phased Locked Loop (PLL).
Frequency Stability:	+/-5 PPM for both the Transmitter/Receiver.
GPS/NMEA:	\$GPGGL/GGA/RMC/GNS sentence is decoded. NMEA Checksum can be turned Off/On.
GPS Display:	Data is selected from following: <ul style="list-style-type: none"> • Date & local time & LL Position (3 digit for seconds). • SOG/COG& LL Position (3 digit for seconds). • Time & Manual LL Position (2 digit for seconds). • No Data.
Data Output:	LL Position from another vessel can be transferred to the DSC equipped chart plotter, if it is connected.
Special Functions:	Three scanning Modes: <ul style="list-style-type: none"> • All Scan • Memory Scan (nonvolatile) • Priority Scan Noisy channels can be temporarily deleted in All Scan Mode. Automatic Auto Calendar for clock. Manual Entry of LL & Time for DSC Emergency Calling. Local Time Offset values can be entered in 30 minute intervals. Instant Access to "Last DSC Call".

TRANSMITTER

Power Output:	25 Watts or 1 Watt switchable.
Tx Current:	6 Amps @ 25W Tx. 1 Amp @ 1W Tx.
Modulation:	G3E for Voice, G3B for DSC Data.
Transmit Frequencies:	156.025Mhz - 157.425Mhz @ 25Khz spacing.
Spurious/Harmonic Emissions:	Less than 0.25 μ W.
Modulation Distortion:	Less than 4% @ 1Khz for +/-3Khz deviation.
Modulation Limiter:	+/-5Khz deviation with 100% modulation.
Frequency Response:	Matches +6dB/Octave slope within +1/-3dB from 300 to 2500Hz. 18dB/Octave beyond 3000Hz. Audio Low Pass Filter is included.
Hum & Noise:	Less than -40dB.

RECEIVER

Receive Frequencies:	156.300Mhz - 162.000Mhz @ 25Khz spacing.
Sensitivity:	0.5 μ V or less for 20dB SINAD
Squelch Range:	0.25 μ V to 0.80 μ V @ full squelch
Audio Output Power:	3.0W minimum @ 4 Ohms with less than 10% distortion.
Receiver Current:	200mA in Standby (2 receivers)
Modulation Acceptance:	+/-7 kHz minimum.
Adjacent Channel Selectivity:	Less than -70dB for +/-25Khz.
Image Rejection:	Less than -70dB.
Intermodulation Spurious Response:	Less than -70dB.
Noise Level:	Less than -40dB unsquelched.
Audio Frequency Response:	Matches -6dB/Octave slope within +1/-3dB from 300 to 2500Hz, 18dB/Octave over 3000Hz.

10.5 Channel Assignments

The Channel Assignment tables on the following pages list the channel number, frequency and usage for Marine VHF communication.

Depending upon your selection, certain channels may be either simplex (single frequency) or duplex (two frequencies) as indicated in the tables. On simplex channels, your transceiver transmits and receives on the same frequency. On duplex channels, your transceiver transmits on one frequency and receives on another frequency. You may communicate with shore stations on both simplex and duplex channels, but because of the frequency offset, you cannot communicate with other vessels on a duplex channel.

Channel 16 is the International Distress, Safety and Calling channel. All vessels equipped with VHF transceivers are required to monitor channel 16.

Table 1 of 2

INTERNATIONAL MARINE VHF CHANNELS					
CH	S/D	TX	RX	CH USAGE	CH NAME
01	D	156.050	160.650	Public correspondence, Port operations and ship movement	INT'L
02	D	156.100	160.700	Public correspondence, Port operations and ship movement	INT'L
03	D	156.150	160.750	Public correspondence, Port operations and ship movement	INT'L
04	D	156.200	160.800	Public correspondence, Port operations and ship movement	INT'L
05	D	156.250	160.850	Public correspondence, Port operations and ship movement	INT'L
06	S	156.300		Inter-ship	SHIP-SHIP
07	D	156.350	160.950	Public correspondence, Port operations and ship movement	INT'L
08	S	156.400		Inter-ship	SHIP-SHIP
09	S	156.450		Inter-ship, Port operations and ship movement	SHIP-SHIP
10	S	156.500		Inter-ship, Port operations and ship movement	SHIP-SHIP
11	S	156.550		Port operations and ship movement	PORT-OPS
12	S	156.600		Port operations and ship movement	PORT-OPS
13	S	156.650		Inter-ship Safety, Port operations and ship movement	SHIP-SHIP
14	S	156.700		Port operations and ship movement	PORT-OPS
15	S	156.750		Inter-ship and On-board communications (1W)	SHIP-SHIP
16	S	156.800		DISTRESS, SEFETY AND CALLING	DISTRESS
17	S	156.850		Inter-ship and On-board communications (1W)	SHIP-SHIP
18	D	156.900	161.500	Public correspondence	PORT-OPS
19	D	156.950	161.550	Public correspondence, Port operations and ship movement	INT'L
20	D	157.000	161.600	Public correspondence, Port operations and ship movement	INT'L
21	D	157.050	161.650	Public correspondence, Port operations and ship movement	INT'L
22	D	157.100	161.700	Public correspondence, Port operations and ship movement	INT'L
23	D	157.150	161.750	Public correspondence, Port operations and ship movement	INT'L
24	D	157.200	161.800	Public correspondence, Port operations and ship movement	INT'L
25	D	157.250	161.850	Public correspondence, Port operations and ship movement	INT'L
26	D	157.300	161.900	Public correspondence, Port operations and ship movement	INT'L
27	D	157.350	161.950	Public correspondence, Port operations and ship movement	INT'L
28	D	157.400	162.000	Public correspondence, Port operations and ship movement	INT'L

Table 2 of 2

INTERNATIONAL MARINE VHF CHANNELS					
CH	S/D	TX	RX	CH USAGE	CH NAME
60	D	156.025	160.625	Public correspondence, Port operations and ship movement	INT'L
61	D	156.075	160.675	Public correspondence, Port operations and ship movement	INT'L
62	D	156.125	160.725	Public correspondence, Port operations and ship movement	INT'L
63	D	156.175	160.775	Public correspondence, Port operations and ship movement	INT'L
64	D	156.225	160.825	Public correspondence, Port operations and ship movement	INT'L
65	D	156.275	160.875	Public correspondence, Port operations and ship movement	INT'L
66	D	156.325	160.925	Public correspondence, Port operations and ship movement	INT'L
67	S	156.375		Inter-ship, Port operations and ship movement	SHIP-SHIP
68	S	156.425		Port operations and ship movement	PORT-OPS
69	S	156.475		Port operations and ship movement	SHIP-SHIP
70	S	156.525		Digital selective calling for distress, safety and calling	
71	S	156.575		Port operations and ship movement	PORT-OPS
72	S	156.625		Inter-ship	SHIP-SHIP
73	S	156.675		Inter-ship	SHIP-SHIP
74	S	156.725		Port operations and ship movement	PORT-OPS
75	S	156.775		Navigation correspondence, Port operations and ship movement (1W)	NAVIGATION
76	S	156.825		Navigation correspondence, Port operations and ship movement (1W)	NAVIGATION
77	S	156.875		Inter-ship	SHIP-SHIP
78	D	156.925	161.525	Public correspondence, Port operations and ship movement	INT'L
79	D	156.975	161.575	Public correspondence, Port operations and ship movement	INT'L
80	D	157.025	161.625	Public correspondence, Port operations and ship movement	INT'L
81	D	157.075	161.675	Public correspondence, Port operations and ship movement	INT'L
82	D	157.125	161.725	Public correspondence, Port operations and ship movement	INT'L
83	D	157.175	161.775	Public correspondence, Port operations and ship movement	INT'L
84	D	157.225	161.825	Public correspondence, Port operations and ship movement	INT'L
85	D	157.275	161.875	Public correspondence, Port operations and ship movement	INT'L
86	D	157.325	161.925	Public correspondence, Port operations and ship movement	INT'L
87	S	157.375		Port operations and ship movement	PORT-OPS
88	S	157.425		Port operations and ship movement	PORT-OPS

EUROPEAN PRIVATE CHANNELS					
CH	S/D	TX	RX	CH USAGE	CH NAME
n ¹	S	157.850		UK Marina Channel 1	UK MARINA1
n ²	S	161.425		UK Marina Channel 2	UK MARINA2
L1	S	155.500		Scandinavia	LEISURE1
L2	S	155.525		Scandinavia	LEISURE2
L3	S	155.650		Scandinavia	LEISURE3
F1	S	155.625		Scandinavia	FISHING1
F2	S	155.775		Scandinavia	FISHING2
F3	S	155.825		Scandinavia	FISHING3
31	D	157.550	162.150	Netherlands Marina Channel (1W)	NL MARINA

M-TECH

www.m-techmarine.com

Manufactured by:

pony
Electric

Pony Electric Corporation
No. 202, 6-28, Akasaka 9-chome
Minato-ku, Tokyo 107-0052, Japan
Phone. +81 (0)3 3405 5733
Fax. +81 (0)3 3405 8677

(C) 2008 Pony Electric Corp. K33091B (English)